

POWER

ELSPRO[®]



CONSULTING · PLANNING · PRODUCTION · SERVICE



INNOVATION · QUALITY · SERVICE

Our basics



Your Partner in the Industry

Since 1986 ELSPRO Elektrotechnik GmbH & Co. KG has been synonymous with high quality and outstanding service in the electricity and lighting sectors. We supply industrial and service clients with an extensive range of innovative electrotechnical safety products.



Tailor-made Solutions

Our specialists implement all customer requirements, if technically feasible. Flexibility and maturity in production processes, which are demand-synchronized, allow us to deliver even tailor-made solutions quickly.

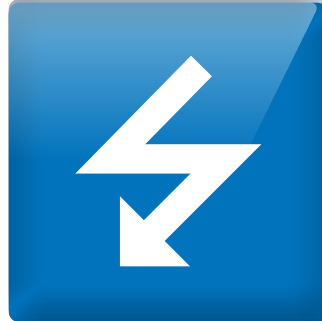

Technology without Compromise

We implement the product requirements of our customers in compliance with the latest technical regulations. Our benchmark is state-of-the-art technology.



Made in Germany

At our headquarter in Hilden, we use the advantages of the neighbouring state capital Düsseldorf in terms of service and logistics. From here we can reach the entire European market quickly and cost-efficiently.



Contact

Mr. Chris Ribjtzki

+49 (0) 21 03 / 97 10-41
 +49 (0) 1 72 / 56 99 636
chris.ribjtzki@elspro.de
[linkedin.com/in/chris-ribjtzki](https://www.linkedin.com/in/chris-ribjtzki)

Your contact for processing offers and orders in the Hilden headquarter:

Customer Care Office

+49 2103 9710-45
sales@elspro.de

Partner to these industries

- ▶ Energy generation
- ▶ Public utilities · Power plants
- ▶ Traffic organisations
- ▶ Emergency and rescue services
- ▶ Construction companies · Assembly
- ▶ Metal working
- ▶ Paper manufacturing and wood processing
- ▶ Chemical industry
- ▶ Food industry
- ▶ Automotive industry
- ▶ Water treatment
- ▶ Shipyards · Plant engineering

1 Mobile Power Distribution Boxes of Solid Rubber
– Floor-Mounted –



2 Stationary Power Distribution Boxes Solid Rubber
– Wall-Mounted –



3 Mobile and Stationary Safety and Isolation Transformers
in Solid Rubber Housing



4 Solid Rubber Cable Reels
Spring Cable Reels
Cable Trolleys



5 Distributors – Special Models



6 Aluminum Energy Columns



7 Plugs with Earthing Contact and CEE Plug Connectors
– Industrial Models –



8 Special Cable Solutions



9 Cable and Hose Bridge Systems
Lightening Protection Bridges

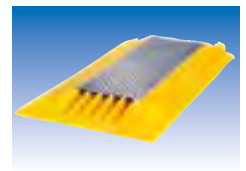

10 Electrical Welding Products
– Plugs, Connectors, Pliers, Cables, Accessories –



Mobile Power Distribution Boxes of Solid Rubber

– Floor-Mounted –



ELSPRO Solid Rubber Safety Distribution Boxes

CELLE

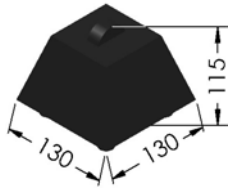

ESSEN

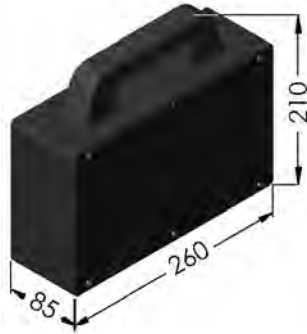

HILDEN

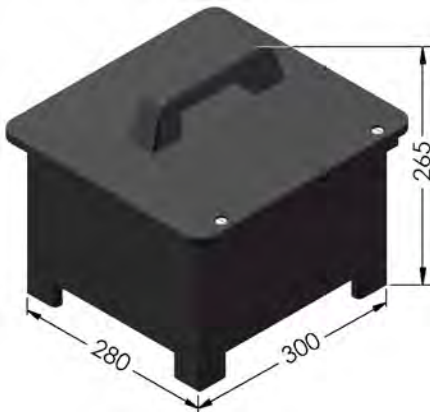

FREIBURG

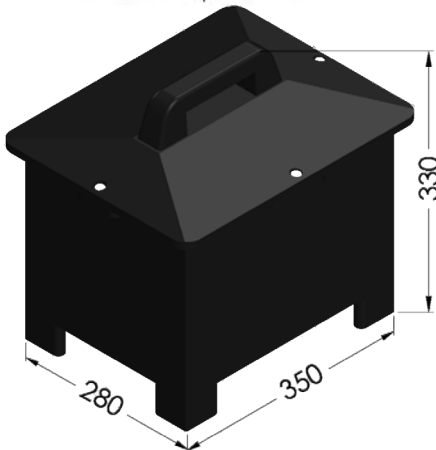

AACHEN



NÜRNBERG

The solid rubber housing is produced using a press and vulcanization process. In combination with the special material employed, this allows us to achieve those qualities that set this distribution box apart.

Housing made of top-quality solid rubber (butyl rubber)

- high mechanical resistance, unbreakable
- hardness of at least 96° Shore in accordance with DIN 53505
- resistant to aging and corrosion
- resistant to acid, lye, grease, and oil
- weatherproof and cold-resistant
- self-extinguishing and fire-resistant according to VDE 0471/DIN EN 60695

Component Features

- VDE-tested connector system
- CEE plug connectors in accordance with VDE 0623/DIN EN 60309 - nickel-plated contact points
- fitted sockets, switches, and all other components are individually exchangeable and fastened using ISO screws
- lid screws made of V2A steel
- rustproof external metal parts

Features of the Assembled Distribution Box

- splashproof
- dustproof
- highly insulated
- maximum protection (IP 65)
- the externally accessible fuse elements are splashproof thanks to a special transparent, shockproof, and self-locking cover
- in compliance with all technical regulations and with all up-to-date electrotechnical safety standards (VDE)

ELSPRO safety distribution boxes are used in a broad range of industrial sectors, wherever high mechanical demands, extreme operating conditions, and heightened safety requirements call for a custom-tailored solution. We will work with you to plan and assemble the product according to your specific requirements and needs. Feel free to contact us – we're happy to help!

The Black Outlet



- to address high demands and safety issues

Range of Application:

Workshop, warehouse, commercial kitchen, laboratory, stage, office, among many other application areas



Models:

Input Plug with Cable	Profile	Length	Output Sockets	Order Number
earthing contact 230 V	3 G 1.5 mm ²	5 m 10 m	3 sockets with earthing contact 	1200030 1200031
earthing contact 230 V	3 G 1.5 mm ²	5 m 10 m	4 sockets with earthing contact 	1200040 1200041

– Cables in INDUSTRIEFLEX® 07 –

Special Features:

- IP 44, highly insulated and splashproof
 - Housing made of polyamide, nylon-reinforced, K2 model
 - Built-in sockets with self-closing hinged lid, 4-point fastening, individually exchangeable
 - for stationary use, the base of the housing features 4 holes to accommodate screws for external mounting
 - dimensions designed for 3 and 4 socket outlets
- SAFE even when used outdoors
 - tread-resistant, shockproof, and impact-resistant, high DURABILITY even under harsh conditions
 - repairs can be made at minimum effort, making it unnecessary to dispose of the entire outlet – COST SAVINGS –
 - simple, stable installation on workbench, office furniture, etc., which heightens the variety of implementation possibilities
 - L 300 mm x W 80 mm x H 68 mm

– other cable lengths and models on request / subject to modification and errors –

You demand superior quality!

Our all-purpose safety distribution box DUISBURG meets your demands – and not only in rough industrial environments. In today’s world, durable and robust safety distribution boxes are needed everywhere – from cafeterias to offices to production settings. And the DUISBURG series caters to both outdoor and indoor working environs.

Guaranteed to ensure health and safety!



S. 5.3

Special Features:

- large carrying handle
 - stable base
 - housing, handle, and base form a compact unit made of solid rubber
 - highly insulated and splashproof
 - extremely robust, shock-resistant, K2 model
- easy and comfortable to carry, handle prevents improper cable transport
 - sockets have better ground clearance when used in wet areas
 - no need for additional fastening measures, for individual parts will absolutely not come loose **MAINTENANCE-FREE**
 - high level of **SAFETY** outdoors and in moist indoor environments
 - long service life, even under rough operating conditions, which equates to **COST SAVINGS!**

Models:

Input Plug with Cable		Output Sockets	Order Number
earthing contact	5 m	4 sockets with earthing contact 	1400001
CEE 230V 16A 3-pol.	5 m		1400002
CEE 400V 16A 5-pol.	3 m		1401001

– other cable lengths and further models on request / subject to modification and errors –

Solid Rubber Housing
Series
CELLE



Number	Output	Sockets	Fuse Protection	Residual Current Circuit Breaker	RCD Type A	Cable	with	Plug	Order No.
		3 sockets with earthing contact	—	—		3 m	earthing contact		1000001
						3 m	CEE 400V 16A 5p.		1001001
		3 CEE 230V 16A 3p.	—	—		3 m	CEE 230V 16A 3p.		1001111
						3 m	CEE 400V 16A 5p.		1001112



		1 CEE 400V 16A 5p. and 2 sockets with earthing contact	—	—		3 m	CEE 400V 16A 5p.		1001103
		3 CEE 400V 16A 5p.	—	—		3 m	CEE 400V 16A 5p.		1001105
		3 CEE 400V 32A 5p.	—	—		3 m	CEE 400V 32A 5p.		1003304



		3 CEE 24V 16A 2p.	—	—		3 m	CEE 24V 16A 2p.		1001106
		3 CEE 42V 16A 2p.	—	—		3 m	CEE 42V 16A 2p.		1001107



		3 CEE 16A 4p. 10h 100-300 Hz	—	—		3 m	CEE 16A 4p. 10h 100-300 Hz		1001108
		3 CEE 16A 4p. 2h 301-500 Hz	—	—		3 m	CEE 16A 4p. 2h 301-500 Hz		1001109



		3 CEE 500V 16A 4p.	—	—		3 m	CEE 500V 16A 4p.		1001110
--	--	--------------------	---	---	--	-----	------------------	--	----------------

– other cable lengths and further models on request / subject to modification and errors –

Configuration Example

Mobile Safety Distribution Boxes



Solid Rubber Housing
Series
ESSEN

Number	Output Sockets	Fuse Protection	Residual Current Circuit Breaker	RCD Type A	Cable	with	Plug	Order No.
--------	----------------	-----------------	----------------------------------	------------	-------	------	------	-----------

3 sockets with earthing contact	3 B-Autom. 1p.	—	3 m	CEE 400V 32A 5p.	1043001
3 CEE 230V 16A 3p.	3 B-Autom. 1p.	—	3 m	CEE 400V 32A 5p.	1043101



1 CEE 400V 16A 5p.	1 C-Autom. 3p	—	3 m	CEE 400V 32A 5p.	1043102
1 CEE 400V 16A 5p.	1 Neokit 3p.	—	3 m	CEE 400V 32A 5p.	1023102
1 CEE 500V 16A 4p.	1 K-Autom. 3p.	—	3 m	CEE 500V 32A 4p.	1043103



1 CEE 400V 16A 5p.	motor protection circuit breaker 3~	—	3 m	CEE 400V 16A 5p.	1091101 1091102 1091103 1091104 1091105
Adjustment Range:	1.6 - 2.4 A	3 m			
	2.4 - 4.0 A	3 m			
	4.0 - 6.0 A	3 m			
	6.0 - 10.0 A				
	10.0 - 16.0 A				



2 m cable with 1 CEE connector socket 400V 16A 5p.	1 C-Autom. 3p	—		CEE 400V 32A 5p.	1043105
	1 Neokit 3p.	—		CEE 400V 32A 5p.	1023104
	1 C-Autom. 3p.	—		CEE 400V 63A 5p.	1046102
	1 Neokit 3p.	—		CEE 400V 63A 5p.	1026102



2 m cable with 1 CEE connector socket 400V 32A 5p.	1 C-Autom. 3p	—		CEE 400V 63A 5p.	1046301
	1 Neozed 3p.	—		CEE 400V 63A 5p.	1026301



– other cable lengths and further models on request / subject to modification and errors –

Solid Rubber Housing
Series
HILDEN

Number	Output	Sockets	Fuse Protection	Residual Current Circuit Breaker RCD Type A	Cable	with	Plug	Order No.
--------	--------	---------	-----------------	---	-------	------	------	-----------



3 sockets with earthing contact			—	25A/30mA/2p.	3 m	earthing contact		1300060
3 sockets with earthing contact			—	3x 25A/30mA/2p.	3 m	earthing contact		1310052



1 CEE 400V 16A 5p.			—	25A/30mA/4p.	3 m	CEE 400V 16A 5p.		1311102
1 CEE 400V 32A 5p.			—	40A/30mA/4p.	3 m	CEE 400V 32A 5p.		1313320



6 sockets with earthing contact			—	40A/30mA/4p.	3 m	CEE 400V 16A 5p.		1311030
1 CEE 400V 16A 5p. 2 earthing contact		2 C-Aut. 1p.	—	40A/30mA/4p.	3 m	CEE 400V 16A 5p.		1351150
1 CEE 400V 16A 5p. 3 earthing contact		—	—	40A/30mA/4p.	3 m	CEE 400V 16A 5p.		1311160



3 sockets with earthing contact		3 B-Aut. 1p.	40A/30mA/4p.	3 m	CEE 400V 32A 5p.			1353030
1 CEE 400V 16A 5p.		1 C-Aut. 3p.	40A/30mA/4p.	3 m	CEE 400V 32A 5p.			1353130
1 CEE 400V 16A 5p. 3 earthing contact		1 C-Aut. 3p. 3 B-Aut. 1p.	—	3 m	CEE 400V 32A 5p.			1343130



1 CEE 400V 16A 5p.		1 C-Aut. 3p.	—	2 m	CEE 400V 63A 5p.			1346130
1 CEE 400V 16A 5p.		1 Neozed 3p.	—	2 m	CEE 400V 63A 5p.			1326130
1 CEE 400V 32A 5p.		1 C-Aut. 3p.	—	2 m	CEE 400V 63A 5p.			1346330
1 CEE 400V 32A 5p.		1 Neozed 3p.	—	2 m	CEE 400V 63A 5p.			1326330

– other cable lengths and further models on request / subject to modification and errors –

Number	Output Sockets	Fuse Protection	RCD Type A Residual Current I _n	Cable with Plug	Order No.
--------	----------------	-----------------	--	-----------------	-----------

6 sockets with earthing contact	6 B-Aut. 1p.	40A/30mA/4p.	3 m	CEE 400V 32A 5p.	1753002
6 sockets with earthing contact	3 Neozed 1p.	40A/30mA/4p.	3 m	CEE 400V 32A 5p.	1733005
6 sockets with earthing contact	—	40A/30mA/4p.	3 m	CEE 400V 16A 5p.	1711001



1 CEE 400V 32A 5p. and 1 CEE 400V 16A 5p. and 3 sockets with earthing contact	— 1 C-Aut. 3p. 3 B-Aut. 1p.	40A/30mA/4p.	3 m	CEE 400V 32A 5p.	1753308
2 CEE 400V 16A 5p. and 3 sockets with earthing contact	1 C-Aut. 3p. 3 B-Aut. 1p.	40A/30mA/4p.	3 m	CEE 400V 32A 5p.	1753102



8 sockets with earthing contact	8 B-Aut. 1p.	40A/30mA/4p.	3 m	CEE 400V 32A 5p.	1853001
1 CEE 400V 32A 5p. and 2 CEE 400V 16A 5p. and 2 sockets with earthing contact	1 C-Aut. 3p. 1 C-Aut. 3p. 2 B-Aut. 1p.	63A/30mA/4p.	3 m	CEE 400V 63A 5p.	1856301



– other cable lengths and further models on request / subject to modification and errors –

Configuration Example

Mobile Safety Distribution Boxes



Solid Rubber Housing
Series
FREIBURG

Number	Output Sockets	Fuse Protection	Residual Current Circuit Breaker	RCD Type A	Cable with Plug	Order No.
--------	----------------	-----------------	----------------------------------	------------	-----------------	-----------

8 sockets with earthing contact	8 B-Aut. 1p.	40A/30mA/4p.	3m	CEE 400V 32A 5p.	1453001
9 sockets with earthing contact	—	40A/30mA/4p.	3m	CEE 400V 16A 5p.	1411004



2 CEE 400V 16A 5p. and 4 sockets with earthing contact	2 C-Aut. 3p. 2 B-Aut. 1p.	40A/30mA/4p.	3m	CEE 400V 32A 5p.	1453113
1 CEE 400V 32A 5p. and 2 CEE 400V 16A 5p. and 3 sockets with earthing contact	— 2 C-Aut. 3p. 2 B-Aut. 1p.	40A/30mA/4p.	3m	CEE 400V 32A 5p.	1453310



2 CEE 400V 32A 5p. and 1 CEE 400V 16A 5p. and 3 sockets with earthing contact	2 C-Aut. 3p. 1 C-Aut. 3p. 3 B-Aut. 1p.	63A/30mA/4p.	3m	CEE 400V 63A 5p.	1456346
2 CEE 400V 32A 5p. and 1 CEE 400V 16A 5p. and 4 sockets with earthing contact	— 1 Neokit 3p. 4 Neokit 1p.	40A/30mA/4p.	3m	CEE 400V 32A 5p.	1433310



1 CEE 400V 63A 5p. and 1 CEE 400V 32A 5p. and 1 CEE 400V 16A 5p. and 3 sockets with earthing contact	— 1 C-Aut. 3p. 1 C-Aut. 3p. 2 B-Aut. 1p.	63A/30mA/4p.	3m	CEE 400V 63A 5p.	1456612
--	---	--------------	----	------------------	----------------



– other cable lengths and models on request / subject to modification and errors –

stackable versions on request



Fig. 1



Fig. 2

with internal protective device

with colored lid on request



SPECIAL FEATURES:

- hinge with a solid V2A axis
 - 2 M6 screws made of V2A steel, undetachable, guaranteeing secure and easy closure of the distribution box
 - four sturdy feet provide 30 mm floor clearance and a firm foothold (Fig. 1)
 - protection guards are arranged clearly under the lid, protecting against accidental contact (Fig. 2)
 - on request: 2 star-handle screws, undetachable, for opening the box without tools (Fig. 3)
 - designed to accommodate a closing mechanism (Fig. 3)
 - inclined and overhanging lid that is also furnished with a rain deflector spanning all sides
 - large, stable carrying handle
 - the inside of the distribution box also displays a clear, maintenance-friendly design
- lid functionality is guaranteed, even when implemented under rough conditions and high mechanical strain
 - protection guards cannot be tampered with by unauthorized persons - SAFETY
 - perfectly suited to nearly all ground conditions
 - live parts cannot be touched, facilitating easy and safe operation
 - trained personnel have quick access to the safety devices - TIME SAVINGS
 - only key holders can open the distribution box
 - rain and spray water cannot build up on the housing
 - thanks to a special shape (recessed grip), the distribution box is comfortable and safe to carry during transport
 - maintenance work can be carried out quickly and simply - COST SAVINGS

with colored engraving on request



Fig. 3

with star-handle screws on request

with a padlock on request



Number	Output Sockets	Fuse Protection	Residual Current Circuit Breaker	RCD Type A	Cable	with	Plug	Order No.
--------	----------------	-----------------	----------------------------------	------------	-------	------	------	-----------

1 CEE 400V 63A 5p. and 2 CEE 400V 32A 5p. and 2 CEE 400V 16A 5p. and 3 sockets with earthing contact	— 2 C-Aut. 3p. 1 C-Aut. 3p. 2 B-Aut. 1p.	—	63A/30mA/4p.	—	3m ---	CEE 400V 63A 5p. or with connector plug	CEE 400V 63A 5p. or with connector plug	1956601 1956602
1 CEE 400V 63A 5p. and 1 CEE 400V 32A 5p. and 2 CEE 400V 16A 5p. and 8 sockets with earthing contact	— 1 C-Aut. 3p. 2 C-Aut. 3p. 4 B-Aut. 1p.	—	63A/30mA/4p.	—	3m ---	CEE 400V 63A 5p. or with connector plug	CEE 400V 63A 5p. or with connector plug	1956603 1956604



2 CEE 400V 32A 5p. and 2 CEE 400V 16A 5p. and 6 sockets with earthing contact	2 C-Aut. 3p. 2 C-Aut. 3p. 6 B-Aut. 1p.	—	63A/30mA/4p. ¹⁾	—	3m ---	CEE 400V 63A 5p. or with connector plug	CEE 400V 63A 5p. or with connector plug	1956301 1956302
1 CEE 400V 32A 5p. and 2 CEE 400V 16A 5p. and 6 sockets with earthing contact	— 2 C-Aut. 3p. 6 B-Aut. 1p.	—	40A/30mA/4p. ¹⁾	—	3m ---	CEE 400V 32A 5p. or with connector plug	CEE 400V 32A 5p. or with connector plug	1953301 1953302
2 CEE 400V 16A 5p. and — waterproof — 6 sockets with earthing contact — water- pressure-tight—	2 C-Aut. 3p. 6 B-Aut. 1p.	—	40A/30mA/4p.	—	3m	CEE 400V 32A 5p. or with — waterproof —	CEE 400V 32A 5p. or with — waterproof —	1953101



– other cable lengths and models on request / subject to modification and errors –

1) externally accessible

stackable versions with folding handle on request



Fig. 1



Fig. 2

with internal protective device

with colored lid on request



SPECIAL FEATURES:

- hinge with a solid V2A axis
 - 3 M6 screws made of V2A steel, undetachable, guaranteeing secure and easy closure of the distribution box
 - 4 sturdy feet provide 40 mm floor clearance and a firm foothold (Fig. 1)
 - protection guards are arranged clearly under the lid, protecting against accidental contact (Fig. 2)
 - on request: 3 star-handle screws, undetachable, for opening the box without tools (Fig. 3)
 - designed to accommodate a closing mechanism (Fig. 4)
 - inclined and overhanging lid that is also furnished with a rain deflector spanning all sides
 - large, stable carrying handle
 - the inside of the distribution box also displays a clear, maintenance-friendly design
- lid functionality is guaranteed, even when implemented under rough conditions and high mechanical strain
 - protection guards cannot be tampered with by unauthorized persons - SAFETY
 - perfectly suited to nearly all ground conditions
 - live parts cannot be touched, facilitating easy and safe operation
 - trained personnel have quick access to the safety devices - TIME SAVINGS
 - only key holders can open the distribution box
 - rain and spray water cannot build up on the housing
 - thanks to recessed grips the distributor sits comfortably and securely in the hand during transport
 - maintenance work can be carried out quickly and simply - COST SAVINGS



Fig. 3

with star-handle screws on request

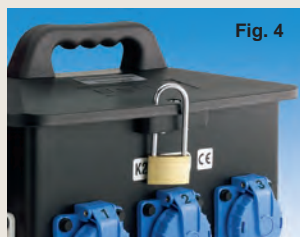

Fig. 4

with a padlock on request

The Giant

- its special construction form together with generous dimensions of 400 x 400 x 275 mm turn the NÜRNBERG series into an ALL-ROUNDER among mobile power distribution boxes
- it's our favorite for feeds of up to 250 A
- the NÜRNBERG series attains its unique style through the frontal array of sockets and the access points for safety and protective devices to the
- an absolute must for all construction and installation sites with high energy demands rear



Configuration examples 1 and 2 of over 300 already assembled varieties

Output/Sockets	Fuse Protection	RCD Type A I_n $I_{\Delta n}$	Infeed Input	Order No.
1 CEE 400V 63 A 5p. 2 CEE 400V 32 A 5p. 2 CEE 400V 16 A 5p. 2 CEE 230V 16 A 3p. 10 sockets with earthing contact	— 2 C-Autom. 3p. 2 C-Autom. 3p. 2 B-Autom. 1p. 10 B-Autom. 1p.	63 A/30 mA/4p.	panel plug 400 V 63 A 5pol. or 3 m feed cable with CEE plug 400 V 63 A 5pol.	1656602 1656601

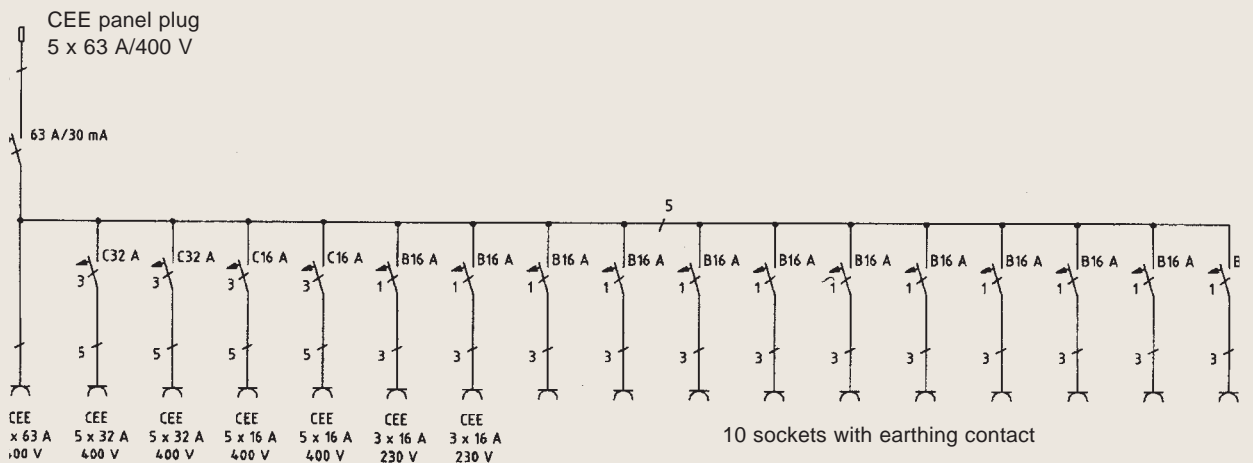

— other models on request / subject to modification and errors —



the shockproof Lexan transparent hinged windows are mounted flush to the lid, which offers protection

Infeed into the distribution box according to customer needs, e.g., lines with plugs, special MC connector system, power lock, etc.



Profile:

- with built-in three-phase meter for in-house cost determination
- with built-in digital or analog gauges, e.g., for measuring time, current, and voltage
- distribution box can be stacked using 2 side-mounted carrying handles (optional)
- with colored engraving for absolutely clear identification of ownership
- stable positioning facilitated through a base with symmetrically arranged grooves to ensure reinforcement and strength
- other typical features on request

Special Features:

- 2 different lids are available
- 1 closed lid for the version with fuse protection situated inside, whereby up to 30 Neozed safety fuses can be mounted under the lid
- 1 lid with 2 shockproof Lexan transparent hinged windows for the versions with fuse protection accessible from the outside; behind the windows there is room for fuses and serial panel plugs of up to 24 TE
- 9 hex bolts M8 X 15 made of V2A steel guarantee secure opening and closing of the lid
- large solid-rubber carrying handles with full-length steel reinforcement, especially suited to transport
- a broad number of diverse transport frames, shafts, carts, etc., significantly enhances usability
- you select the solution that optimally suits your needs PRACTICABILITY
- fuse replacement is possible (though only by a specialized electrician) after opening the lid with a tool - SAFETY
- easy and accidental-contact-protected access to the safety and protective devices thanks to flip-open windows - TIME SAVINGS
- no-rust screws that can be loosened even after years - MAINTENANCE FREE
- handles withstand even heavy strain and will not tear - SAFETY
- an individual approach to easy and secure transport is possible, as well as safe mounting - MULTI-DISTRIBUTOR

The Giants on Wheels

- up to 3 housings can be combined
e.g., NÜRNBERG - NÜRNBERG (see fig.)
NÜRNBERG - WIESBADEN
NÜRNBERG - TRIER
- the selection of possible versions doubles
- all trolleys are protected against corrosion; plastic powder coating of all iron and steel components has proven to be especially effective; color used is blue, RAL 5013
- 2 wheels of solid rubber, each 200 mm in diameter and ball-bearing mounted, facilitate smooth and effortless movement of the distribution boxes, even on rough stretches
- the center of gravity during transport is optimally situated above the axle midpoint; only one person is needed to transport the box safely, easily, and without any (weight-related) health risks
- extra wide radii for hand navigation and bends additionally enhance trolley safety
- various different wheels are also available



Configuration examples 1 and 2 of over 300 already assembled varieties

Output/Sockets	Fuse Protection	RCD Type A 	Infeed Input	Order No.
2 CEE 400V 63 A 5p. 4 CEE 400V 32 A 5p. 4 CEE 400V 16 A 5p. 10 sockets with earthing contact	2 Neozed 3p. 4 Neozed 3p. 5p. 4 Neozed 3p. 3 Neozed 1p. — fuses situated inside —	125 A/30 mA/4p.	panel plug 125 A 400 V 5pol.	1637601

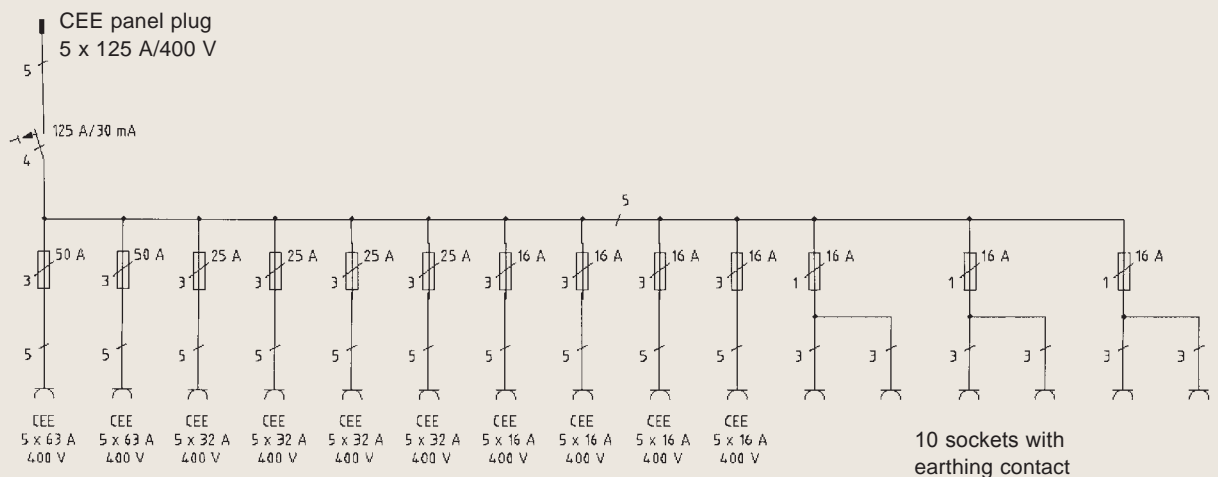

— other cable lengths and further models on request / subject to modification and errors —

The XXL Distribution Box

The stable base frame and the generous clearance are just two of the many outstanding features that distinguish the HAMBURG distribution box.

Additionally, more than one connection housing can be installed under the distribution box (see fig.). This significantly enhances the technical possibilities.

5.150 cm² of area are available for individual configurations and serve to facilitate the implementation of complex application profiles.

Frame design is adaptable to individual demands, including a trolley version.

These features make HAMBURG the No. 1 XXL series among mobile power distributors.



Dimensions: footprint 80 cm x 80 cm
overall height 112,5 cm

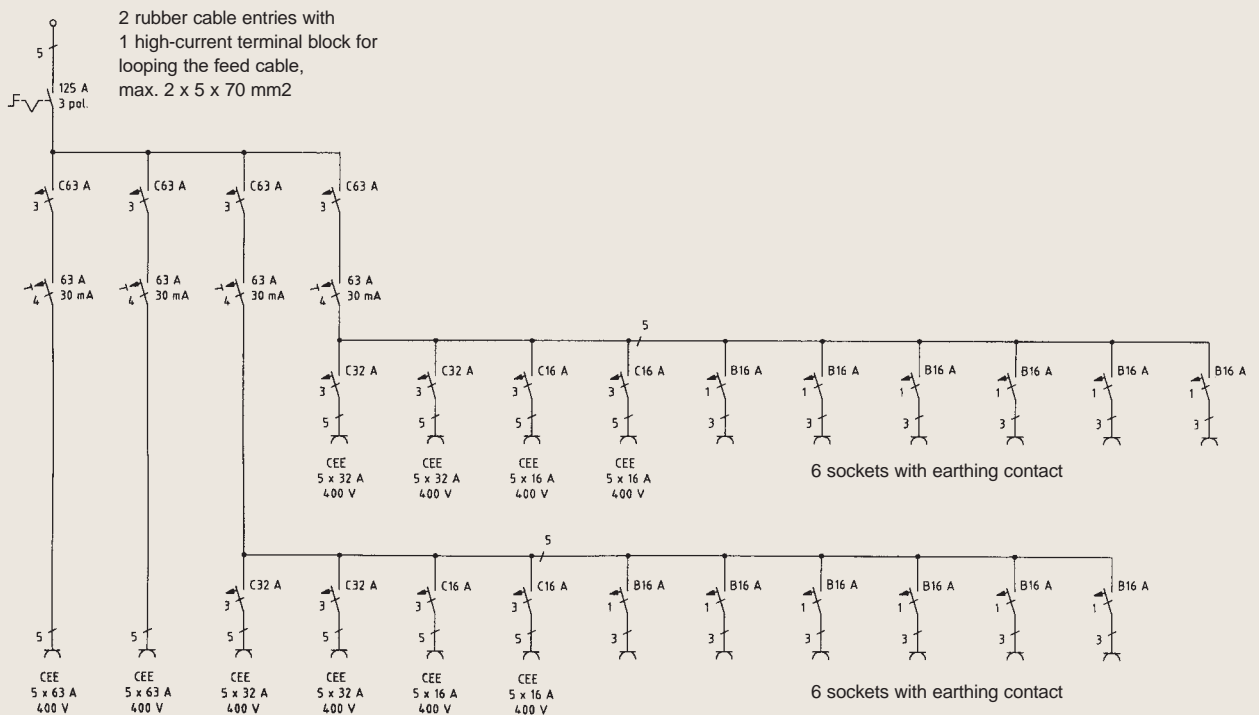

– other models on request / subject to modification and errors –

— The overhanging lid serves to deflect rain and is connected to the base by 16 V2A hex bolts, M8 x 20 mm.



— Residual current protection guards and automats are designed to be accessible from the outside, splashproof, protected behind transparent hinged windows, self-closing, and additionally secured with knurled-head screws.



— one high-current terminal block for laying max. 2 cables/lines, cross-section 5 x 70 mm², with ring cable lugs of 8 mm Ø

— Halfen anchoring system for mounting clips



— the tubular steel frame is hot-dip galvanized - other models on request -

— featuring double crossbars for secure transport with a forklift

— 2 cable entry grommets

— various housings and configurations in the product range

Configuration Example

Output/Sockets	Fuse Protection	RCD Type A 	Infeed max. 125 A Input	Order No.
2 CEE 400V 63 A 5p. 4 CEE 400V 32 A 5p. 4 CEE 400V 16 A 5p. 12 sockets with earthing contact	2 C-Autom. 3p. 4 C-Autom. 3p. 4 C-Autom. 3p. 12 B-Autom. 1p. 2 C-Autom. 3p. — backup fuses —	4 x 63A/30 mA/4p.	2 high-current terminal block for laying 1 high-current terminal block for laying 2 cables/lines max. 5 x 70 mm ²	1559601
1 main switch 125A/3pol.				

— other models on request / subject to modification and errors —

Stationary Power Distribution Boxes – Solid Rubber and Wall-Mounted



ELSPRO Solid Rubber Safety Distribution Boxes

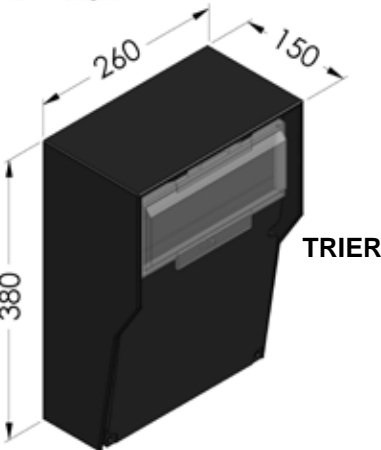
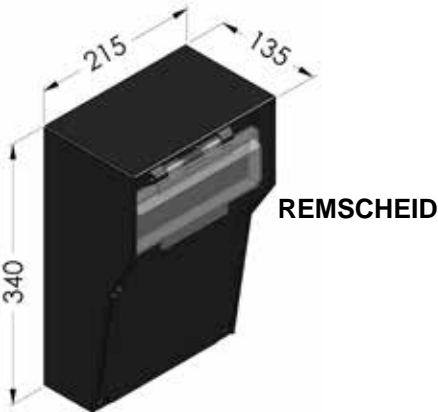

Housing made of top-quality solid rubber (butyl rubber)

- high mechanical resistance, unbreakable
- hardness of at least 96° Shore in accordance with DIN 53505
- resistant to aging and corrosion
- resistant to acid, lye, grease, and oil
- weatherproof and cold-resistant
- self-extinguishing and fire-resistant according to VDE 0471/DIN EN 60695

Component Features

- VDE-tested connector system
- CEE plug connectors in accordance with VDE 0623/DIN EN 60309 - nickel-plated contact points
- fitted sockets, switches, and all other components are individually exchangeable and fastened using ISO screws
- lid screws made of V2A steel
- rustproof external metal parts

Features of the Assembled Distribution Box

- splashproof
- dustproof
- highly insulated
- maximum protection (IP 65)
- the externally accessible fuse elements are splashproof thanks to a special transparent, shockproof, and self-locking cover
- in compliance with all technical regulations and with all up-to-date electrotechnical safety standards (VDE)

ELSPRO safety distribution boxes are used in a broad range of industrial sectors, wherever high mechanical demands, extreme operating conditions, and heightened safety requirements call for a custom-tailored solution. We will work with you to plan and assemble the product according to your specific requirements and needs. Feel free to contact us – we're happy to help!

Configuration Example

Mobile Safety Distribution Boxes



Solid Rubber Housing
Series
ESSEN

Number	Output Sockets	Fuse Protection or Equipment	RCD Type A Residual Current	Entry Screw Size	Order No.
--------	----------------	------------------------------	-----------------------------	------------------	-----------

4 sockets with earthing contact	—	—	25A/30mA/2p.	M 20	2018001
1 CEE 400V 16A 5p. and 4 sockets with earthing contact	—	—	—	M 20	2008101
1 CEE 400V 32A 5p. and 2 sockets with earthing contact	2 B-Autom. 1p.	—	—	M 20	2048301



4 sockets with earthing contact	— quick-release connector	—	—	M 20 1/2 inch thread	2008001
1 CEE 400V 16A 5p. and 3 sockets with earthing contact	— quick-release connector	—	—	M 20 1/2 inch thread	2008102



2 sockets with earthing contact	—	—	25A/30mA/2p	M 20	2018002
1 CEE 400V 16A 5p. and 2 sockets with earthing contact	—	—	—	M 20	2008103
1 CEE 400V 32A 5p. and 2 sockets with earthing contact	2 B-Autom. 1p.	—	—	M 20	2048302



1 screw sized M 25	main switch 40A 400V 3 ~	—	—	M 25	2008801
1 screw sized M 20	reverse switch 40A 400V 3 ~	—	—	M 25	2008802
1 screw sized M 20	emergency push button	—	—	M 25	2008804



– other cable lengths and further models on request / subject to modification and errors –



Solid Rubber Housing

Series
HILDEN

Configuration Example

Suspension and Wall-mounted Distribution Boxes



Number	Output	Sockets	Fuse Protection or Equipment	RCD Type A / Residual Current Circuit Breaker	Entry	Screw Size	Order No.
2 sockets with earthing contact			—	25A/30mA/2p.	M 20		2318073
3 sockets with earthing contact			—	25A/30mA/2p.	M 20		2318072
3 sockets with earthing contact			—	40A/30mA/4p.	M 20		2318070
4 sockets with earthing contact			4 B-Autom. 1p.	—	M 25		2348030



1 CEE 400V 16A 5p. 2 sockets with earthing contact			— 2 B-Autom. 1p.	40A/30mA/4p.	M 32		2358150
1 CEE 400V 32A 5p. 2 sockets with earthing contact			— 2 B-Autom. 1p.	40A/30mA/4p.	M 32		2358314



1 CEE 400V 16A 5p.			—	40A/30mA/4p.	M 20		2318160
1 CEE 400V 32A 5p.			—	40A/30mA/4p.	M 25		2318320



1 screw sized M 25			—	40A/30mA/4p.	M 25		2318830
1 screw sized M 32			—	63A/30mA/4p.	M 32		2318840

– other cable lengths and further models on request / subject to modification and errors –



Solid Rubber Housing
Series
REMSCHIED

Number	Output Sockets	Fuse Protection or Equipment	RCD Type A Residual Current I _n	Entry	Screw Size	Order No.
--------	----------------	------------------------------	--	-------	------------	-----------

6 sockets with earthing contact	6 B-Autom. 1p.	40A/30mA/4p.	M 25	2758010
6 sockets with earthing contact	6 Neokit 1p.	40A/30mA/4p.	M 25	2738002
6 sockets with earthing contact	9 B-Autom. 1p.	—	M 25	2748001



1 CEE 400V 16A 5p. and 3 sockets with earthing contact	1 C-Autom. 3p. 3 B-Autom. 1p.	40A/30mA/4p.	M 25	2758144
1 CEE 400V 32A 5p. and 3 sockets with earthing contact	1 C-Autom. 3p. 3 B-Autom. 1p.	63A/30mA/4p.	M 32	2758350
1 CEE 400V 16A 5p. and 3 sockets with earthing contact	1 Neokit 3p. 3 Neokit 1p.	40A/30mA/4p.	M 25	2738115



1 CEE 400V 32A 5p. and 1 CEE 400V 16A 5p. and 3 sockets with earthing contact	— 1 C-Autom. 3p. 3 B-Autom. 1p.	40A/30mA/4p.	M 32	2758340
1 CEE 400V 32A 5p. and 1 CEE 400V 16A 5p. and 3 sockets with earthing contact	1 C-Autom. 3p. 1 C-Autom. 3p. 3 B-Autom. 1p.	—	M 32	2748302



1 CEE 400V 63A 5p. and 2 sockets with earthing contact	— 2 B-Autom. 1p.	63A/30mA/4p.	M 32	2758607
1 CEE 400V 63A 5p.	1 C-Autom. 3p.	63A/30mA/4p.	M 32	2758601
1 CEE 400V 63A 5p.	—	63A/30mA/4p.	M 32	2718601



– other models on request / subject to modification and errors –



Configuration Example

Suspension and wall-mounted distribution boxes

Solid Rubber Housing
Series
TRIER

Number

Output

Sockets

Fuse
Protection or
Equipment

Residual Current
Circuit Breaker
RCD Type A

Entry
Screw Size

Order No.



8 sockets with earthing contact	8 B-Autom. 1p.	40A/30mA/4p.	M 25	2858001
12 sockets with earthing contact	12 B-Autom. 1p.	—	M 25	2848001



1 CEE 400V 32A 5p. and 1 CEE 400V 16A 5p. and 4 sockets with earthing contact	1 C-Autom. 3p. 1 C-Autom. 3p. 2 B-Autom. 1p.	63A/30mA/4p.	M 32	2858301
2 CEE 400V 16A 5p. and 4 sockets with earthing contact	2 C-Autom. 3p. 2 B-Autom. 1p.	63A/30mA/4p.	M 32	2858153



1 CEE 400V 32A 5p. and 1 CEE 400V 16A 5p. and 2 sockets with earthing contact	1 C-Aut. 3p. 1 C-Aut. 3p. 2 B-Aut. 1p.	63A/30mA/4p.	M 32	2858316
1 CEE 400V 32A 5p. and 1 CEE 400V 16A 5p. and 6 sockets with earthing contact	1 C-Autom. 3p. 1 C-Autom. 3p. 6 B-Autom. 1p.	—	M 32	2848301

– other models on request / subject to modification and errors –

Number	Output Sockets	Fuse Protection or Equipment	RCD Type A Residual Current	Entry	Screw Size	Order No.
--------	----------------	------------------------------	-----------------------------	-------	------------	-----------

1 CEE 400V 32A 5p. and 2 CEE 400V 16A 5p. and 2 sockets with earthing contact	1 C-Autom. 3p. 1 C-Autom. 3p. 2 B-Autom. 1p.	63A/30mA/4p.			M 32	2858374
1 CEE 400V 32A 5p. and 2 CEE 400V 16A 5p. and 2 sockets with earthing contact	1 C-Autom. 3p. 1 C-Autom. 3p. 2 B-Autom. 1p.	—			M 32	2848302



1 CEE 400V 63A 5p. and 1 CEE 400V 32A 5p. and 1 CEE 400V 16A 5p. and 2 sockets with earthing contact	— 1 C-Autom. 3p. 1 C-Autom. 3p. 2 B-Autom. 1p.	63A/30mA/4p.			M 32	2858601
---	---	--------------	--	--	------	----------------



4 CEE 400V 16A 5p.	4 C-Autom 3p.	—			M 32	2848125
4 CEE 400V 32A 5p.	4 C-Autom 3p.	—			M 32	2848303



– other cable lengths and further models on request / subject to modification and errors –



- Lexan transparent hinged windows
 - V2A axis, 6 mm Ø
 - stainless-steel spring with high elastic force
 - with knurled-head screws on request

The solid rubber housing is produced using a press and vulcanization process. In combination with the special material employed, this allows us to achieve those qualities that set this distribution box apart.

Dimensions: H 380 mm, W 260 mm, D 150 mm

Special Features:

- over 600 already produced versions guarantee a custom-tailored solution on demand
 - interior space allows cross-sections to be connected (up to 35 mm²) and 2 cables to be laid (5 x 35 mm²) - feed and outgoing lines
 - 6 undetachable lid screws made of V2A steel allow the lid to be attached to the base tightly and securely
 - under the impact-resistant Lexan transparent hinged windows there is room for panel plugs and fuses up to max. 12 TE
 - protruding housing sections in the window area protect the window against mechanical damage
 - wall-mounted distribution boxes are available with a broad range of options: shafts, racks, tripods, and wall-mounted consoles; hot-dip galvanized, painted, or plastic-powder-coated; made of steel or V2A steel; various sizes and forms
- no compromises
PRACTICABILITY
 - the supply cables can be honed, which enables one to do without additional junction boxes
TIME AND COST SAVINGS
 - no-rust screws that can be loosened anytime -
MAINTENANCE FREE
 - measures for safeguarding people, devices, and cables as well as short-circuit protection all conform to valid regulations
SAFETY
 - no additional protective cover necessary
COST REDUCTION
 - **ENERGY ISLANDS** for all purposes and sites. Optimally suited for outdoor use as well.
LONG SERVICE LIFE guaranteed

ACCESSORIES:

- V2A wall-mounting brackets (pre-installed on request)

You demand superior quality!

Our wall-mounted distribution boxes meet your demands.

In all sectors - industry, trade, and commerce - sockets are needed that prove to be durable, sturdy, and safe.

Our wall-mounted distribution boxes are suitable for both indoor and outdoor use.



Configuration examples 1 and 2 of over 130 already assembled varieties

Output/Sockets	Fuse Protection	RCD Type A I _n I _{Δn}	Entry Screw Size	Order No.
1 CEE 400V 63 A 5p. 1 CEE 400V 32 A 5pol. 2 CEE 400V 16 A 5pol. 4 sockets with earthing contact	1 Neozed 3p. 1 C-Autom. 3p. 1 C-Autom. 3p. 3 B-Autom. 1p.	63 A/30 mA/4p.	1 x M50 or 2 x M50 with main branch terminal 2 x 5 x 35 mm ²	28786002 28786001

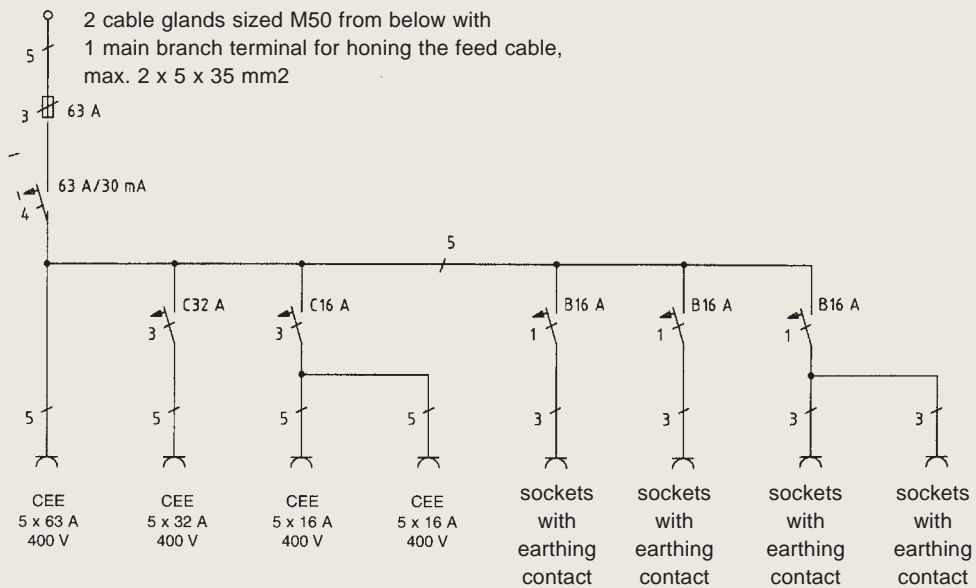

– other models on request / subject to modification and errors –

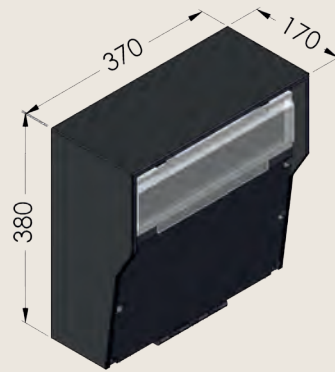

- V2A axis, 6 mm Ø
- stainless-steel spring with high elastic force
- undetachable knurled-head screws



The solid rubber housing is produced using a press and vulcanization process. In combination with the special material employed, this allows us to achieve those qualities that set this distribution box apart.

Special Features:

- over 130 configurations guarantee a solution for (almost) every operating site
 - generous interior space and a depth of 95 mm allow for the connection of large cross-sections and for the installation of feed and outgoing lines
 - a hinged lid facilitates unimpeded access during installation and maintenance work
 - 9 undetachable lid screws made of V2A steel ensure that the lid is securely fastened to the base
 - over 130 configurations guarantee a solution for (almost) every operating site
 - under the impact-resistant Lexan transparent hinged windows there is room for panel plugs and fuses up to max. 18 TE
 - protruding housing sections in the window area offer enhanced protection for the window
 - wall thickness of up to 15 mm and the special material employed make the distribution box extremely mechanically sturdy and impact-resistant
- no compromises
PRACTICABILITY
 - junction boxes no longer necessary
COST SAVINGS
 - TIME SAVINGS
 - the distribution box can be effortlessly opened and closed, even after years have passed
 - measures for safeguarding people and cables as well as short-circuit protection all conform to valid regulations
 - measures for safeguarding people and cables as well as short-circuit protection all conform to valid regulations
 - no additional protective cover necessary
 - long service life, even under rough operating conditions

- other models on request / subject to modification and errors -

Safety and Isolation Transformers in Solid Rubber Housing



ELSPRO Solid Rubber Distribution Boxes with Transformers

Safety Transformers and Isolation Transformers according to VDE 0570 / DIN EN 61558

- Housing Features

- made of top-quality solid rubber (butyl rubber)
- high mechanical resistance, unbreakable
- hardness of at least 96 Shore in accordance with DIN 53505
- resistant to aging and corrosion
- weatherproof and cold-resistant
- self-extinguishing and fire-resistant according to VDE 0471/DIN EN 60695

- Transformer Selection

- one-phase transformers or multi-phase transformers
- input voltage 12 V to 500 V
- output voltage 12 V to 500 V
- nominal capacity 120 VA to 4500 VA

- Primary Safeguards

- activating a thermal overcurrent circuit breaker matched to the primary current
- optimal transformer protection in the case of an overload or short circuit
- reliable switch performance thanks to special switching mechanism
- positively trip-free mechanism
- switch reset at the press of an external button after error has been corrected

- Secondary Safeguards

- fuses assigned to output sockets
- choice of line circuit breaker or safety fuse systems
- accessible both externally and internally

- Connector Systems

- VDE tested and approved
- nickel-plated contacts
- individually exchangeable
- fastened with ISO bolts

- Features of Assembled Distribution Boxes

- splashproof
- highly insulated
- dustproof
- lid screws made of V2A steel
- rustproof external metal parts

- with colored engraving on request, e.g. company name

Time-current characteristic (total switch-off time at nominal voltage) Ambient temperature 23°C

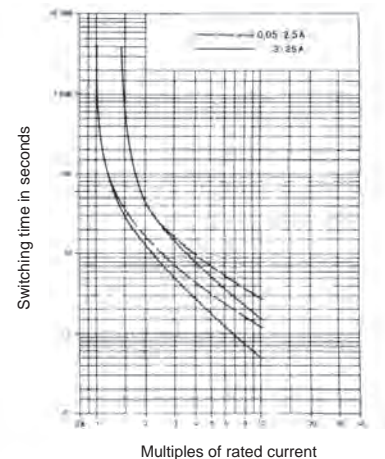

Safety Transformers

from 120VA-4500VA



Mobile Protection Class 2



CE **K2**
Solid Rubber Housing
 Series

Volt-Ampere Power	Input* Voltage ~	Output Voltage ~	No.	Sockets Output	Input 	Output 	Order No.
----------------------	---------------------	---------------------	-----	-------------------	-----------	------------	-----------

120 VA	230V	24V		CEE 24V 16A 2p.	0,5A	—	3080101
120 VA	230V	42V		CEE 42V 16A 2p.	0,5A	—	3080102



160 VA	230V	24V	1	CEE 24V 16A 2p.	0,7A	—	3380170
160 VA	230V	24V	2	CEE 24V 16A 2p.	0,7A	—	3380185
350 VA	230V	24V	1	CEE 24V 16A 2p.	1,5A	—	3380186
350 VA	230V	24V	2	CEE 24V 16A 2p.	1,5A	—	3380165



160 VA	230V	42V	1	CEE 42V 16A 2p.	0,7A	—	3380183
160 VA	230V	42V	2	CEE 42V 16A 2p.	0,7A	—	3380171
350 VA	230V	42V	1	CEE 42V 16A 2p.	1,5A	—	3380169
350 VA	230V	42V	2	CEE 42V 16A 2p.	1,5A	—	3380182



500 VA	230V	24V	2	CEE 24V 16A 2p.	2,0A	2 Neozed 1p.	3480101
750 VA	230V	24V	3	CEE 24V 16A 2p.	3,0A	3 Neozed 1p.	3480102
1000 VA	230V	24V	4	CEE 24V 16A 2p.	4,0A	4 Neozed 1p.	3480103
500 VA	230V	42V	2	CEE 42V 16A 2p.	2,0A	—	3480104
750 VA	230V	42V	3	CEE 42V 16A 2p.	3,0A	—	3480105
1000 VA	230V	42V	4	CEE 42V 16A 2p.	4,0A	2 Neozed 1p.	3480106



1500 VA ¹⁾	230V	24V	4	CEE 24V 16A 2p.	6,0A	4 Neozed 1p.	3980105
2000 VA ¹⁾	230V	24V	6	CEE 24V 16A 2p.	8,0A	6 Neozed 1p.	3980101
2500 VA ¹⁾	230V	24V	6	CEE 24V 16A 2p.	10,0A	6 Neozed 1p.	3980102
1500 VA ¹⁾	230V	42V	4	CEE 42V 16A 2p.	6,0A	4 Neozed 1p.	3980106
2000 VA ¹⁾	230V	42V	6	CEE 42V 16A 2p.	8,0A	6 Neozed 1p.	3980103
2500 VA ¹⁾	230V	42V	6	CEE 42V 16A 2p.	10,0A	6 Neozed 1p.	3980104



3 m feed line with contour plug
 1) inrush current limiter

– other models on request / subject to modification and errors –



CE **K2**
Solid Rubber Housing
 Series NURNBERG

Volt-Ampere Power	Input* Voltage ~	Output Output	Sockets Output	Input 	Output 	Order No.
----------------------	---------------------	------------------	-------------------	-----------	------------	-----------



3000 VA	230V	24V	10 CEE 16A 2p.	13A	10 B-Autom. 1p.	3640101
4000 VA	230V	24V	10 CEE 16A 2p.	16A	10 B-Autom. 1p.	3640109



3000 VA	230V	24V	10 CEE 16A 2p.	13A	10 B-Autom. 1p.	3640102
4000 VA	230V	24V	10 CEE 16A 2p.	16A	10 B-Autom. 1p.	3640110

all models with inrush current limiter



Profile:

- 2 large carrying handles with full-length steel reinforcement ensure secure transport and allow the unit to be carried by 2 people
- the frontal array guarantees unimpeded access to all sockets, even when high in number
- in the distribution box interior, carrier elements and lateral rods ensure necessary support for the heavy transformers
- all fixtures are smoothly and easily accessible by a specialized electrician for on-demand maintenance
- all one-phase transformers are equipped with an inrush current limiter in order to avoid inadvertent tripping of the mains fuse (e.g., B automats)
- an added heat protection tube (H07 V-K for all insulated wires) permanently rules out isolation errors and short circuits in the wiring
- a broad number of different transport carts counts among the available accessories
- further outstanding features and qualities distinguish the ELSPRO safety and isolation transformers and guarantee high quality and safety standards

Safety Transformers

from 120VA-2000VA

Wall-Mounted



Volt-Ampere
Power

Input*
Voltage ~

Output
Voltage ~

No.

Sockets
Output

Input



Output



Order No.



Solid Rubber Housing
Series

160 VA	230V	24V	1 CEE 24V 16A 2p.	0,7A	—	3388164
160 VA	230V	24V	2 CEE 24V 16A 2p.	0,7A	—	3388167
350 VA	230V	24V	1 CEE 24V 16A 2p.	1,5A	—	3388168
350 VA	230V	24V	2 CEE 24V 16A 2p.	1,5A	—	3388161



HILDEN

160 VA	230V	42V	1 CEE 42V 16A 2p.	0,7A	—	3388170
160 VA	230V	42V	2 CEE 42V 16A 2p.	0,7A	—	3388169
350 VA	230V	42V	1 CEE 42V 16A 2p.	1,5A	—	3388162
350 VA	230V	42V	2 CEE 42V 16A 2p.	1,5A	—	3388166



HILDEN

500 VA	230V	24V	2 CEE 24V 16A 2p.	2,0A	2 B-Aut. 1p.	3748102
500 VA	230V	42V	2 CEE 42V 16A 2p.	2,0A	—	3788106



REMSCHIED

1000 VA	230V	24V	3 CEE 24V 16A 2p.	4,0A	3 B-Aut. 1p.	3848101
2000 VA	230V	24V	6 CEE 24V 16A 2p.	8,0A	6 B-Aut. 1p.	3848102
- not illustrated -						
1000 VA	230V	42V	3 CEE 42V 16A 2p.	4,0A	3 B-Aut. 1p.	3848103
2000 VA	230V	42V	6 CEE 42V 16A 2p.	8,0A	6 B-Aut. 1p.	3848104
- not illustrated -						



TRIER

— other models on request / subject to modification and errors —

*screw size M

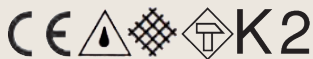

Solid Rubber Housing Series

Power	Volt-Ampere Input* Voltage ~	Output	Sockets	Cable Length Meters	Cross-Section mm ²	Light Type	Order No.
-------	------------------------------------	--------	---------	---------------------------	----------------------------------	------------	-----------



LRX

50 VA	230 V*	24 V	0,2 A	30	2 x 2,5	HSW ¹	3X80903
		42 V				on request	
50 VA	230 V*	24 V	0,2 A	30	2 x 2,5	QS ²	3X80905
		42 V				on request	



LRX

* 3 m special line INDUSTRIEFELX 07HT 2 x 1,0 mm² with contour plug



LRK

** cable gland M20

50 VA	230 V**	24 V	0,2 A	30	2 x 2,5	HSW ¹	3188947
		42 V				QS ²	3188948
							on request

The power cable is firmly connected.
With easily removable illuminated lamp!
The safety transformer is laterally flange-mounted.
Low voltage of 24 V is conducted through collector rings.

1 = solid rubber handheld led lamp	9 W	24 V	HSW LED (page 21.11)
2 = inspection lamp	20 W	24 V	QS L05 (page 21.21)

– other models on request / subject to modification and errors –

Isolation Transformers

from 120VA-4500VA

Mobile Protection Class 2

CE    **K2**
Solid Rubber Housing
 Series

Volt-Ampere	Input*	Output	No.	Sockets	Input	Output	Order No.
Power	Voltage ~	Voltage ~		Output			

120 VA	230V	230V		1 socket with earthing contact -without  -	0,5 A	—	3080001
--------	------	------	--	---	-------	---	----------------





125 VA	230V	230V		1 socket with earthing contact -without  -	0,5 A	—	3380006
--------	------	------	--	---	-------	---	----------------





350 VA	230V	230V		1 socket with earthing contact -without  -	1,5 A	—	3380005
--------	------	------	--	---	-------	---	----------------



500 VA	230V	230V		1 socket with earthing contact -without  -	2,0 A	—	3480001
750 VA	230V	230V		1 socket with earthing contact -without  -	3,0 A	—	3480002
1000 VA	230V	230V		1 socket with earthing contact -without  -	4,0 A	—	3480003



1500 VA ¹⁾	230V	230V		1 socket with earthing contact -without  -	6,0 A	—	3980003
2000 VA ¹⁾	230V	230V		1 socket with earthing contact -without  -	8,0 A	—	3980001
2500 VA ¹⁾	230V	230V		1 socket with earthing contact -without  -	10 A	—	3980002



* 3 m feed line with contour plug
¹⁾ inrush current limiter

– other models on request / subject to modification and errors –



Solid Rubber Housing
Series NURNBERG

Volt-Ampere Power	Input* Voltage ~	Output Output	Sockets Output	Input 	Output 	Order No.
----------------------	---------------------	------------------	-------------------	-----------	------------	-----------



3000 VA	1) 230V	230V	1 socket with earthing contact —without	13A	—	3680005
3500 VA	1) 230V	230V	1 socket with earthing contact —without	15A	—	3680001
4000 VA	1) 230V	230V	1 socket with earthing contact —without	16A	—	3680002

with inrush current limiter



4000 VA	2) 400V 3~	400V 3~	1 CEE 400V 3~ 16A	6A 3p.	—	3681101
4500 VA	2) 400V 3~	400V 3~	1 CEE 400V 3~ 16A	6A 3p.	—	3681102



Profile of Order No. 5691003

Mobile isolation transformer in an ELSPRO solid rubber distribution box on a trolley from the NÜRNBERG series

Input: 3 m cable INDUSTRIEFLEX® 07 with CEE plug 5 x 16 A/400 V

Fixtures: 1 three-phase transformer with 3 separate output windings

Primary power: 4500 VA, 3x400 V

Second power: 3x1500 VA, 3x230 V single-phase

Switching group: Diii Nominal frequency: 50-60 Hz

- primary safeguarding via a motor protection switch 6 A/3-pol.

Output: 3 sockets with earthing contact; also secured without earthing contact by way of 3 MCB 6 A/1 pol. in B type

- each with an engraved caution sign:

ATTENTION!

Connect only 1 consumer to each earthing contact socket!

Model Features:

- K2 type
- highly insulated
- the circuit breakers are externally accessible and are situated behind 2 transparent hinged windows for protection
- the steel frame of the trolley features a plastic powder coating
- 2 ball-bearing-mounted solid rubber tires, 200 mm in diameter
- compact structural shape and favorable center of gravity
- transformer according to VDE 0570
- splashproof

1) 3 m feed line with contour plug
2) 3 m feed line with CEE plug, 400 V 16 A 5p.

Isolation Transformers

from 120VA-2000VA

Wall-Mounted Distribution Boxes



CE
Solid Rubber Housing
 Series

Volt-Ampere	Input*	Output	No.	Sockets	Input	Output	Order No.
Power	Voltage ~	Voltage ~		Output			

125 VA	230V	230V		1 socket with earthing contact -without -	0,5 A	—	3388011
160 VA	230V	230V		1 socket with earthing contact -without -	0,7 A	—	3388012



350 VA	230V	230V		1 socket with earthing contact -without -	1,5 A	—	3388010
--------	------	------	--	---	-------	---	----------------



500 VA	230V	230V		1 socket with earthing contact -without -	2,0 A	—	3788004
--------	------	------	--	---	-------	---	----------------



1000 VA	230V	230V		1 socket with earthing contact -without -	4,0 A	—	3888001
2000 VA -without fig.-	230V	230V		1 socket with earthing contact -without -	8,0 A	—	3888002



* screw size M

– other models on request / subject to modification and errors –

Solid Rubber Cable Reels Spring Cable Reels Cable Trolleys



ELSPRO Solid Rubber Cable Reels

suitable for rough operating conditions in industry, trade, and at construction sites

- according to DIN VDE 0623, section 100/EN61316
- reel body made of solid rubber
 - maintenance-free and unbreakable
 - cold-resistant and thermally stable
 - highly flame-resistant and self-extinguishing
 - resistant to corrosion, oil, acid, and lye
 - utterly weatherproof and ageing resistant
- kink-free cable entry
- heavy-duty strain relief for push, pull, and against torsion
- steel-tube frame
 - ergonomic
 - robust
 - stable
 - plastic powder coated
- insulated carrying handle
- inside parking and dispensing brakes
- highly insulated and splashproof
- cable type: INDUSTRIEFLEX[®]07 HT - see reg. no. 8
- with colored engraving on request

Connector System

- VDE-test and certified
- nickel-plated contacts
- individually replaceable
- fastened with ISO bolts

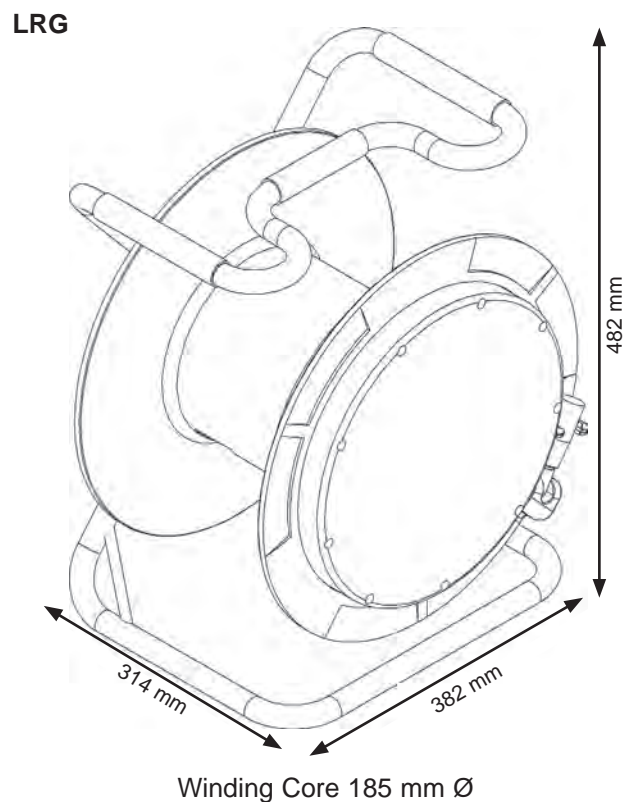
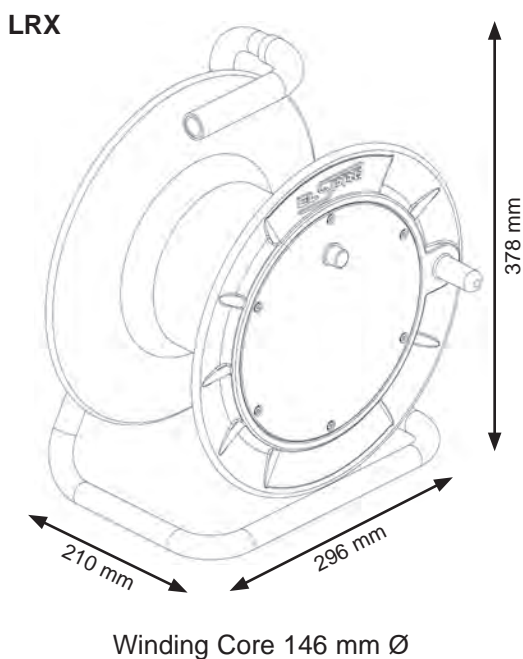

LRX

our number 1



ELSPRO®

SPECIAL FEATURES

- $K + M = X$ → advantages of the proven LRK and LRM series combined in one cable reel
- new compact industrial design
- optimised shape, weight reduction and ergonomics
- large front cover for many variants, e.g. max. 5 x sockets with earthing contact
- front cover with injected PU seal
- adapted shape protects the brake wing screw
- optimised/small gap size between frame and reel body prevents jamming of the cable
- with internal locking and unwinding brake, braking efficiency adjustable by means of the wing screw (see diagrams below)
- soft cable entry prevents wire breaks by means of generous bending radii
- with overheating protection
- LED with switch optionally for initial lighting or illumination of a small construction site
- carrying frame optionally with clamping shell feet
- robust and stable tube frame, plastic powder coated
- protectively insulated and splash-proof
- compliant with the test principle in accordance with GS-ET-35 (principles for the testing and certification of cable reels for construction and installation sites)

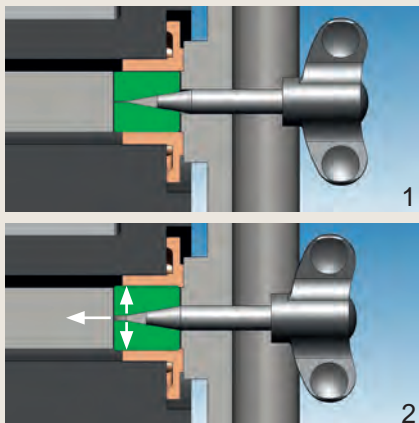

Principle of the Inside Brake:

- The wing screw has a tapered tip that rests between the two brake blocks (see fig. 1).
- By screwing in the wing screw, the brake blocks are pressed apart (see fig. 2) and exert force on the nylon bearing bush, which in turn is tightly connected to the rubber reel body.
- Braking pressure can be continually increased by turning the wing screw.
- If the wing screw is turned back, then pressure on the brake is reduced and the brake blocks return to their original position.

– other models on request / subject to modification and errors –

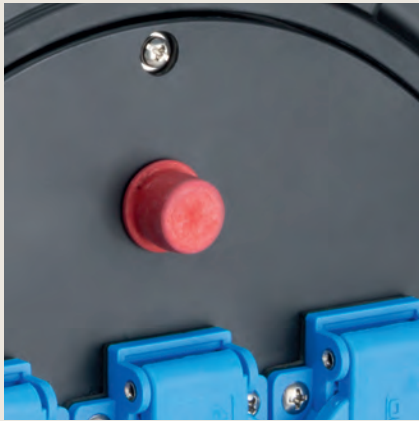

with overheating protection



insulated carrying handle



equipment variants with different safety features possible



the shape of the carrying frame protects the wing screw of the internal brake from damage



alternatively with integrated LED light with switch



the optimised gap size between carrying frame and reel body prevents jamming and possible damage to the cable



the large front cover allows many different equipment variants



optionally with clamping shell feet

– other models on request / subject to modification and errors –

Solid Rubber Cable Reels

with overheating protection

Series LRX

Configuration Examples



Number

Output

Sockets

Cable Length
Meters

Cross-Section
mm²

Plugs

Order No.



3 sockets with earthing contact	25	3 G 1,5	with earthing contact	4X00001
	33			4X00002
	40			4X00003
	50			4X00004
3 sockets with earthing contact	25	3 G 2,5	with earthing contact	4X00021
	33			4X00022
	40			4X00023
	50			4X00027



optionally in IP67

3 sockets with earthing contact IP 66/68	25	3 G 1,5	with earthing contact IP 66/68	4X00041
	33			4X00042
	40			4X00043
	50			4X00044
3 sockets with earthing contact IP 66/68	25	3 G 2,5	with earthing contact IP 66/68	4X00061
	33			4X00062
	40			4X00063
	50			4X00066



2 sockets with earthing contact LED + switch	25	3 G 1,5	with earthing contact	4X00081
	33	3 G 1,5		4X00082
	40	3 G 1,5		4X00083
	50	3 G 1,5		4X00084



3 sockets with earthing contact with PRCD-S	25	3 G 1,5	with earthing contact	4X10001
	33			4X10002
	40			4X10003
	50			4X10004
3 sockets with earthing contact with PRCD-S	25	3 G 2,5	with earthing contact	4X10021
	33			4X10022
	40			4X10023
	50			4X10025

– other models on request / subject to modification and errors –

Series LRX		Configuration Examples			Solid Rubber Cable Reels	
Number	Output Sockets	Cable Length	Meters	Cross-Section mm ²	Plugs	Order No.

with overheating protection



2 sockets with earthing contact 1 RCD Type A / 25 A / 30 mA	25	3 G 1,5	with earthing contact	4X10051
	33			4X10052
	40			4X10053
	50			4X10054
2 sockets with earthing contact 2 RCB Type A / 16 A / 30 mA 2 pol. / C-Char.	25	3 G 1,5	with earthing contact	4X10072/C
	33			4X10074/C
2 sockets with earthing contact 2 RCB Type A / 16 A / 30 mA 2 pol. / C-Char.	25	3 G 2,5	with earthing contact	4X10073/C
	33			4X10075/C



1 CEE 400 V / 16 A / 5 p. 2 sockets with earthing contact	25	5 G 2,5	CEE 400 V / 16 A / 5 p.	4X01111
	33			4X01112



2 CEE 24 V / 16 A / 2 p.	25	2 x 2,5	CEE 24 V / 16 A / 2 p.	4X01121
2 CEE 24 V / 16 A / 2 p.	33	2 x 4,0	CEE 24 V / 16 A / 2 p.	4X01122
	40			4X01123
2 CEE 42 V / 16 A / 2 p.	25	2 x 2,5	CEE 42 V / 16 A / 2 p.	4X01141
	33			4X01142
2 CEE 42 V / 16 A / 2 p.	40	2 x 4,0	CEE 42 V / 16 A / 2 p.	4X01143



3 sockets with earthing contact IP 66/68 1 RCD Type A / 25 A / 30 mA	25	3 G 1,5	with earthing contact IP 66/68	4X10046
	33			4X10047
	40			4X10048
	50			4X10049
3 sockets with earthing contact IP 66/68 1 RCD Type A / 25 A / 30 mA	25	3 G 2,5	with earthing contact IP 66/68	4X10076
	33			4X10077
	40			4X10078
	50			4X10079



– other models on request / subject to modification and errors –

EXPLODED DRAWING:

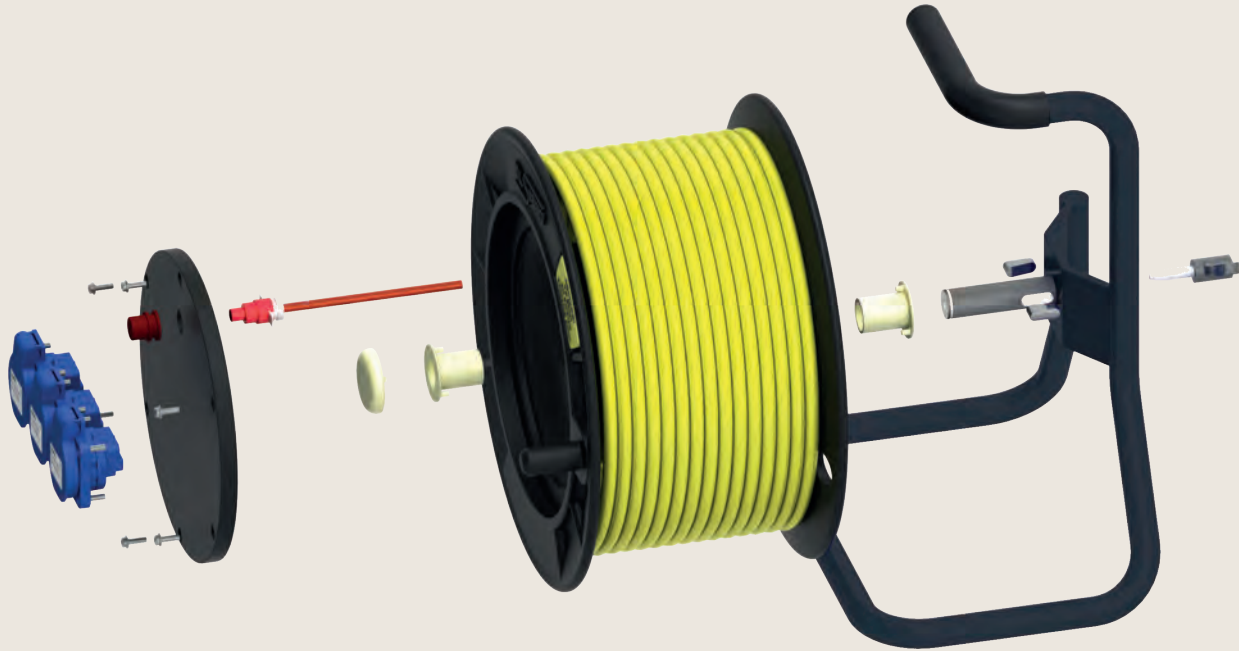

DIMENSIONS:

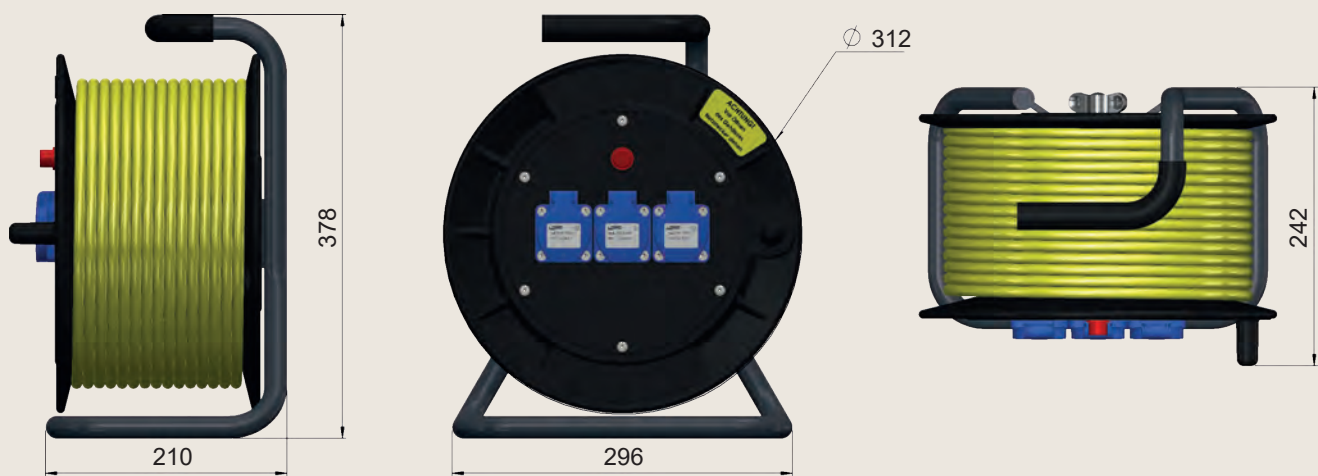

– other models on request / subject to modification and errors –

Configuration Examples

Series LRG

Solid Rubber Cable Reels

with overheating protection
1 pol. / 3 pol.



Number	Output	Sockets	Cable	Length Meters	Cross-Section mm ²	Plugs	Order No.
--------	--------	---------	-------	------------------	----------------------------------	-------	-----------

4 sockets with earthing contact (no fig.)			60		3 G 2.5	with earthing contact	4G02203
2 CEE 400V 16A 5p. and 3 sockets with earthing contact			50		5 G 2.5	CEE 400V 16A 5p.	4G01107



1 CEE 400V 32A 5p. and 1 CEE 400V 16A 5p. protected with 1 C-Autom. 3p. and 3 sockets with earthing contact protected with 3 B-Autom. 1p. 1 residual-current circuit breaker RCD Type A I _n =40A I _{Δn} =30mA 4p.			40		5 G 6.0	CEE 400V 32A 5p.	4G53324
---	--	--	----	--	---------	------------------	----------------



1 CEE 400V 32A 5p. - waterproof - and 2 CEE 400 V 16A 5p. - waterproof - protected with 2 C-Autom. 3p. and 1 socket with earthing contact - water-pressure-tight - protected with 1 B-Autom. 1p.			40		5 G 6.0	CEE 400V 32A 5p. - waterproof -	4G43332
--	--	--	----	--	---------	---------------------------------	----------------



5 CEE 42V 16A 2p.			80		2 G 4.0	CEE 42V 16A 2p.	4G01132
4 CEE 42V 16A 2p.			50		2 G 4.0	CEE 42V 16A 2p.	4G01114
4 CEE 24V 16A 2p.			50		2 G 4.0	CEE 24V 16A 2p.	4G01112



– other models on request / subject to modification and errors –

ELSPRO Solid Rubber Cable Reels Series LRG



Back-friendly, bilateral transport by two people

Testing standard GS-ET-35 specifies that the overall mass of a cable reel being appropriately transported by one person without auxiliary means cannot exceed 25 kg!

The following apply as well:

- Directive 90/269/EWG
- Load Handling Regulation (LasthandhabV)
- German Occupational Safety Act (ArbSchG)
- DIN EN 1005-2 „Safety of machinery - Human physical performance - Part 2: Manual handling of machinery and component parts of machinery“
- BGHM-I 101 (BGI 523)
- Exposure Limit Values 2019 – Safety and Health in the Workplace (IFA Report 1/2019)

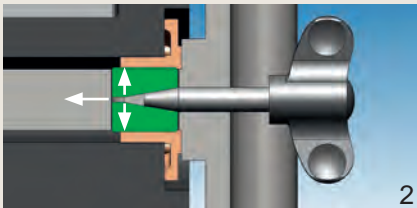
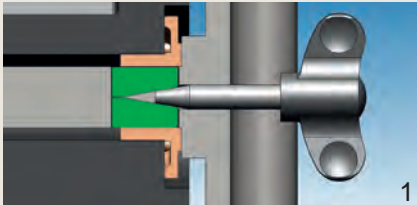

Principle of the Inside Brake:

- The wing screw has a tapered tip that rests between the two brake blocks (see fig. 1).
- By screwing in the wing screw, the brake blocks are pressed apart (see fig. 2) and exert force on the nylon bearing bush, which in turn is tightly connected to the rubber reel body.
- Braking pressure can be continually increased by turning the wing screw.
- If the wing screw is turned back, then pressure on the brake is reduced and the brake blocks return to their original position.

Meets various special requirements where an interior brake is necessary on cable reels, e.g., German Federal Agency for Technical Relief (THW), German Red Cross (DRK), etc.

ACCESSORIES:

Order No.

- Stainless-steel trolley with solid rubber wheels and rubberized handle

JOG48



Even 40 kg can be moved effortlessly:
hook up – tilt – ready to go



Number	Output	Sockets	Cable Length	Meters	Cross-Section	mm ²	Plugs	Order No.
1	CEE 400V 32A 5p. with 1 residual-current circuit breaker RCD Type A $I_n=40A I_{\Delta n}=30mA$ 4p.		40		5G6.0		CEE 400V 32A 5p.	4813301
on the frame:								
1 solid rubber wall-mounted distribution box with feed cable and plug								
1 CEE 400V 32A 5pol. and 1 CEE 400V 16A 5pol. and 3 earthing contact sockets protected with 1 C-Autom. 3p. 3 B-Autom. 1p.								



Characteristics and Special Features:

- A foldable rotary handle for easy reeling in of the cable
- large solid rubber front panel with integrated rubber seal and eight lid screws made of V2A steel with an M4 thread
- wear-free nylon bushing guarantees easy and even running of the reel body along the axis
- robust and sturdy tubular carrying frame, fashioned from a single piece of metal and powder-coated
- favorable center of gravity and the ergonomic handle foster high carrying comfort
- conforms to VDE 0623-100, DIN EN 61316
- carrying handle, rotary handle, and reel body made of insulating material according to DGUV 203-006 / 203-004
- for models with three-phase sockets, the 3 pol. overheating protection runs via an interior power contactor
- for models with a residual-current circuit breaker (RCD), deactivation due to overheating is carried out by the RCD



– other models on request / subject to modification and errors –

ELSPRO Cable Reeling Drums Typ LR600F and LR700F



LARGE cable cross-sections

LONG cable lengths

Easy to do with the “THE 2”!

Temporary power supply must often be achieved using large cable cross-sections and long cable lengths. These cables are then so heavy that they cannot be handled by one person alone.

The “THE 2” reels offer optimal support in laying and neatly rolling up again even the heaviest and longest of cables, making the process manageable and time-saving as well. The operational readiness of the lines is therefore consistently ensured.

Frame

The plastic-powder-coated steel frame is designed to be torsion-resistant in order to ward against mechanical impact. A stable bar serves as a grip.

Tires

Stable footing and facile movement of the cable reel are promoted through two solid rubber fixed wheels and two solid-rubber castor wheels, each with a wheel diameter of 200 mm.

Type	Model	Dimensions (L x W x H)	Weight	Order No.
LR600F LR600F	without cable * 40 m cable 5 G 16 mm ²	700 x 600 x 800 mm 700 x 600 x 800 mm	78.0 kg 137.0 kg	LR600F LR600F/CS40K6
LR700F LR700F LR700F	without cable * 150 m cable 5 G 16 mm ² ** 80 m cable 5 G 35 mm ²	1,050 x 700 x 800 mm 1,050 x 700 x 800 mm 1,050 x 700 x 800 mm	90.0 kg 312.0 kg 315.0 kg	LR700F LR700F/CS150K6 LR700F/CS80KX

* with CEE plug and CEE connector 400V 63A 5p.

** with CEE plug and CEE connector 400V 125A 5p.

– other models on request / subject to modification and errors –

ELSPRO Cable Reeling Drums Type LR 600 F and LR 700 F

1 Hand-Operated Safety Crank Handle

- when not in use, the handle is disengaged
- handle is engaged through axial movement (pressing motion)
- by “letting go” of the handle, it automatically disengages

2 Chain-Protection Cover

The chain is situated under a protective cover to prevent the user from touching the chain drive and the braking system, which could lead to accidental injury.

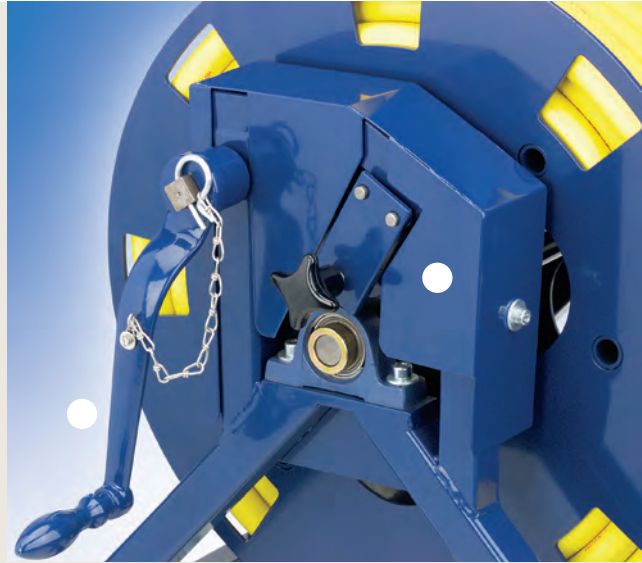

3 Chain Drive with Two Gear Wheels

The chosen gear transmission ration (10:44) for the two gear wheels is designed to ensure easy reeling in, even in the case of heavy loads (“one-man operation”).

4 Braking System

The fixed and saddle brakes with their brake pads exert pressure on the large gear wheel that is situated along the drum axle. The brake caliper distributes force continuously with even flow along both sides of the gear wheel.

5 Ball-Bearing Mounted Drum Body

The stable, ball-bearing-mounted axle of the drum body is enclosed by two pedestal bearings. This allows the heavy drum body to turn with ease and avoids wear.

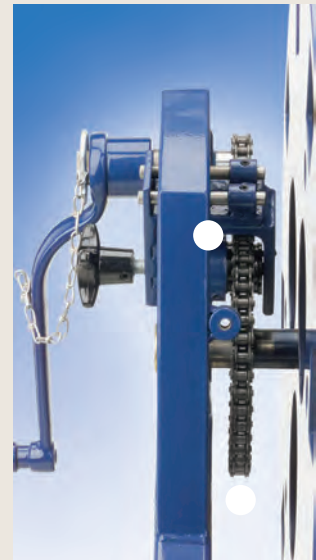

Advantages ...

- the crank handle only induces traction force at the drive shaft during active use; by contrast, when the shaft is unintentionally activated, the disengaged handle does not turn
- chain drive and braking system are fully encased
- chain drive with gear transmission ratio of 10:44
- ball-bearing mounted drum body

... and Benefits:

- no risk of injury due to unintentionally rotating crank handle!
- no risk of injury from drive since it is inaccessible!
- one-man operation possible!
- even-flowing braking effect and drive protection due to continuous strain; accidental unreeling is prevented, and readying the cable made easier: “cable flow as smooth as possible – as strong as necessary!”
- smooth, protective unreeling

– other models on request / subject to modification and errors –

Spring hose reels – the solution for more safety and cleanliness in the workplace

Fields of Application:

- industry
- trade
- commerce

Disorganized cables lying on the ground, often a cause of accidents, are a thing of the past. Cables that are not needed for the time being are securely and neatly rolled up until the next project. Delivered with a locking mechanism in place. The cable can be fixated at almost any length and thus allows for a traction-free working experience. The locking mechanism can be deactivated when necessary.



Type	Voltage	Input	Output	Dimensions (W x H x D)	Order No.
SYLT 1	230 V	bend-protection grommet	12 m cable 3 G 1.5 mm ² with earthed connector	170 x 315 x 350 mm	4689001SI
SYLT 2	230 V	bend-protection grommet	17 m cable 3 G 1.5 mm ² with earthed connector	180 x 375 x 400 mm	4689050SII

SPECIAL FEATURES:

- versatile installation possibilities for wall, floor, and ceiling
- closed, corrosion-free housing made of polyoxymethylene; drum made of polypropylene
- highly insulated and splashproof
- with a wall console that can be swiveled at 160°
- spring encapsulated in a cassette
- safety locking device that can be switched on or off by hand
- 3 collector rings (L1-N-PE), max. 10 ampere
- overheating protection switch with manual reset
- adjustable cable stopper
- equipped with flexible INDUSTRIEFLEX® 07 cable
- flexible mounting of the spring cable reels according to operating site and workplace
- long service life, even under extremely rough operating conditions: **COST SAVINGS!**
- high measure of electrical **SAFETY**, even outdoors and in damp spaces
- smooth motion in all directions guarantees excellent handling while also protecting the cable
- simple and danger-free replacement without needing special tools
- if safety locking device is activated, the cable can be tightly fixated at any given unreeled length
- dual contact system for the PE conductor = double the **SAFETY**
- when line overload occurs, power is shut down **FIRE PROTECTION**
- protection against back-reeling of the entire line; individual length adjustment of sagging cable
- extended service life of the reeled up cable; for detailed features and qualities, see register group 8

– other models on request / subject to modification and errors –

Spring cable reels alleviate tripping hazards that arise from lines lying on the ground. Neatly wound cables not only facilitate a convenient and safe working environment but also protect the materials used. Cables that are left lying around are frequently run over or subjected to heightened mechanical strain. This results in premature wear and tear of the materials.

What advantages do spring cable reels offer?

- reduction of accident risks
- efficient use of materials
- longer service life = cost reduction



Voltage	Input	Output	Order No.
230 V	1.0 m power supply cable 3 x 2.5 mm ²	25 m cable 3 G 2.5 mm ² with earthed connector	4685010A
400 V	1.0 m power supply cable 5 x 2.5 mm ²	22 m cable 5 G 2.5 mm ² with CEE connector 5 x 16A/400V	4685110A

SPECIAL FEATURES:

- versatile installation options for wall, floor, and ceiling
- galvanized steel tube frame and corrosion-free drum made of fiberglass-reinforced plastic
- sprayproof cable reel; splashproof standard connector system models
- cable discharge via 4 reels, adjustable to 60°
- encapsulated spring
- exterior, removable 7-fold locking mechanism
- 5 collector rings (L1-N-PE) with carbon brushes, max. 10 ampere
- adjustable cable end stop
- equipped with flexible INDUSTRIEFLEX® 07 cable
- flexible mounting of the spring cable reels according to operating site and workplace
- long service life, even under extremely rough operating conditions: **COST SAVINGS!**
- perfectly suited for safe implementation, even outdoors and in damp spaces
- low-abrasion cable routing protects the cable and extends its service life: **COST SAVINGS**
- simple and danger-free replacement without needing special tools
- if safety locking device is activated, the cable can be tightly fixated at almost any given unreeled length and offers a traction-free working experience; if the locking system is dismantled, the cable is constantly subject to tension
- excellent low-maintenance and safe contact system
- protection against back-reeling of the entire line; individual length adjustment of sagging cable
- extended service life of the reeled up cable; for detailed features and qualities, see register group 8

– other models on request / subject to modification and errors –

Spring hose reels are the effective solution for more safety and cleanliness at the workplace

Fields of Application:

- **industry**
- **trade**
- **commerce**

Disorganized hoses lying on the ground frequently cause work-related accidents. Spring hose reels promote order in the workplace, which helps avoid dangerous tripping hazards and protects the materials used.

Air and water hoses are securely and neatly rolled up, ready to use at any time.

Delivered with a locking mechanism in place. The hose can be fixated at almost any length and thus allows for a traction-free working experience. The locking mechanism can be deactivated when necessary.



Type	Input	Output	max. operating pressure MPa (bar)	Dimensions (W x H x D)	Order No.
BORKUM 1	connection nozzle for 3/8" hose	12 m 1/4" hose with connection thread	1.2 (12)	170x315x350mm	4602201BI



Type	Input	Output	max. operating pressure MPa (bar)	Dimensions (W x H x D)	Order No.
BORKUM 2	connection nozzle for 3/8" hose	10 m 3/8" hose with connection thread	1.5 (15)	180x375x400mm	4602250BII

SPECIAL FEATURES:

- versatile installation possibilities for wall, floor, and ceiling
- closed, corrosion-free housing made of polyoxymethylene; drum made of polypropylene
- includes a wall bracket with 160° swivel range
- spring encapsulated in a cassette
- safety locking device that can be switched on or off by hand
- with adjustable hose stopper
- equipped with heavy-duty PUR/PVC hose featuring cord reinforcement
- flexible mounting of the spring cable reels according to operating site and workplace
- long service life, even under extremely rough operating conditions: **COST SAVINGS!**
- smooth motion in all directions protects the hose while offering superb handling
- simple and danger-free replacement without needing special tools
- if safety locking device is activated, the hose can be tightly fixated at any given unreeled length
- protection against back-reeling of the entire line; individual length adjustment of sagging hose
- high durability, long service life

– other models on request / subject to modification and errors –

Spring hose reels – the solution for more safety and cleanliness

- fewer work accidents
- less hose wear
- more efficient use of materials

Spring hose reels provide enhanced order in the work-place and reduce the risk of accidents that are frequently caused by hoses lying around on the floor in an unorganized way.

Neatly rolling up hoses between work projects serves to protect materials and heighten durability.



Input	Output*	Order No.
connection nozzle for 1/2" hose	15 m 3/8" hose with hose clamp	4602201F

* models available with 1/4" and 1/2" hoses

SPECIAL FEATURES:

- versatile installation possibilities for wall, floor, and ceiling
 - galvanized tube frame and corrosion-free drum made of fiberglass-reinforced plastic
 - hard-wearing grommet made of brass and stainless steel
 - encapsulated spring
 - removable 5-fold drum locking mechanism
 - hose discharge via four reels, adjustable
 - adjustable hose stopper
 - equipped with heavy-duty PUR/PVC hose featuring cord reinforcement for max. pressure of 1.5 Mpa (15 bar)
- flexible mounting of the spring cable reels according to operating site and workplace
 - long service life, even under extremely rough operating conditions: **COST SAVINGS!**
 - high durability and therefore reduction of maintenance costs
 - maintenance-friendly and safe; simple and danger-free replacement without needing special tools
 - thanks to a safety locking device, the cable can be tightly fixated at almost any given unreeled length and offers a traction-free working experience; if the locking system is dismantled, the air hose is constantly subject to tension
 - low mechanical load on the hose, less abrasion, **EXTENDED SERVICE LIFE**
 - protection against back-reeling of the entire hose line; individual length adjustment of sagging hose
 - high durability, long service life

– other models on request / subject to modification and errors –

Distributors - Special Models according to DGUV informations 203-006 and 203-032



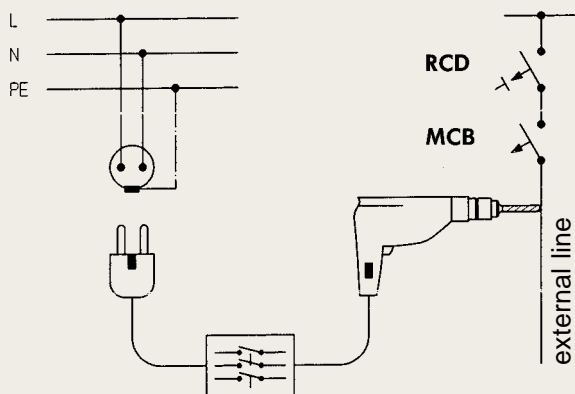

- drilling into external lines
- full protection through safety measures in the external line
- PRCD-S detects the external voltage on the protective earthing yet without interrupting the protective earthing connection, thus allowing the external voltage to be activated through its own upstream RCD and MCB safety devices

Use and Function

Especially for construction and installation sites, fire departments and emergency services.

- encapsulated models for rough operating conditions
- suitable for direct connection with the feed cable of the electrical device (H07 RN-F 3G 2.5 mm²)
- can be implemented independently of whichever plug system is being used
- large, easy-to-use ON and OFF buttons
- additional optical switch position display
- undervoltage release
- extremely short trigger time
- splashproof according to IP 55
- long service life even when subjected to excessive strain
- unit cannot be operated without personal protection if safety precautions are compulsory
- plug types can be changed without needing to make a new purchase **COST SAVINGS**
- simple and safe operation
- operational status is easy to discern
- prevention of uncontrolled restarting of machines after power returns
- the user's protection level is heightened
- designed for use in damp areas

Technical Data:

Rated voltage: 230 V/50 Hz	Nominal Current: 16 A	Protection Class: max. IP 55	Conductor Cross-Section: 1 mm ² to 2.5 mm ²
Nominal Fault Current: 10 or 30 mA	Ambient Temperature: -25° to 40° C with a daily mean value that does not exceed 35° C	Norms and Standards: - DIN VDE 0661 - DIN 40040 or DIN EN 60721	

- in accordance with rules for safety and health protection as specified by the DGUV (DGUV Information 203-006): "Selection and operation of electrical installations and equipment on building and installation sites"

Technical Data about:

- PRCD-S (Personal Safety Switch)
- Solid Rubber Cable Reels
- INDUSTRIEFLEX® 07 HT Cables
- ELSPRO Solid Rubber Safety Distribution Boxes

on Pages:

- 5.1/5.2
- 4.0
- 8.2
- 1.0



Fig. 1

SPECIAL FEATURES:

- when the PRCD-S is turned on, the socket that serves as a feed point is assessed to ensure proper functioning, for example:
 1. the protective earthing conductor must be available and voltage-free
 2. the phase and the neutral conductor must be in contact (undervoltage release)
- the PRCD-S (personal safety switch) cannot be switched on after an error has been discovered
 - an even higher degree of security is achieved, even when the equipment is supplied with power from unknown networks or uncontrolled sockets
 - after a power failure incident, protection is offered to ensure that connected handheld instruments do not automatically shut on once power is returned, thus preventing damage
 - an endangerment of persons due to errors in permanent installations is avoided; electrical equipment cannot be used until the error has been corrected

Input Plug with Cable		PRCD-S 30 mA	Output Cable with ... and sockets		Order Number	Fig.
solid rubber earthing sockets angle plug	0,2 m		25 m	solid rubber cable reel 3 earthing contact sockets	4X10001	1
solid rubber earthing sockets angle plug	0,2 m		5 m	DUISBURG solid rubber distributor with 4 earthing contact sockets	5410001	2
solid rubber earthing sockets	1,5 m		3 m	CELLE solid rubber distributor with 3 earthing contact sockets	5310001	3



Fig. 2



Fig. 3

– INDUSTRIEFLEX® 07 HT cables–

– other cable lengths and further models on request / subject to modification and errors –

The PRCD-S (Portable Residual Current Protective Device - Safety) offers electronic residual current analysis and is run as a portable protective system device between lines that is capable of switching between poles. It is designed for alternating currents, pulsating direct currents, and phase-controlled nominal fault currents of 10 and 30 mA, with undervoltage release, protective earthing identification and monitoring, as well as external voltage recognition.



*PRCD = Portable Residual Current Protective Device is a new general term used even in German-speaking regions.

Models:

Input Plug – water-pressure-tight – with Cable		PRCD-S 30 mA	Output Cable with Connector – water-pressure-tight –		Order Number
none	—		—	none	PD 03
earthing contact sockets	1.5 m		3.0 m	earthing contact sockets	PD 03/S 1,5 K3

— INDUSTRIEFLEX®07 cables —
 — other cable lengths and further models on request / subject to modification and errors —

Extent of protection provided by the PRCD-S:

1. For errors in the connected electrical device, protection is provided in accordance with DIN VDE 0661. Residual currents caused by defective contact lead the PRCD-S to carry out all-pole disconnection.
2. Equipment failure in the case permanent installations: the PRCD-S detects all possible errors in permanent installations and then refuses to be switched on.

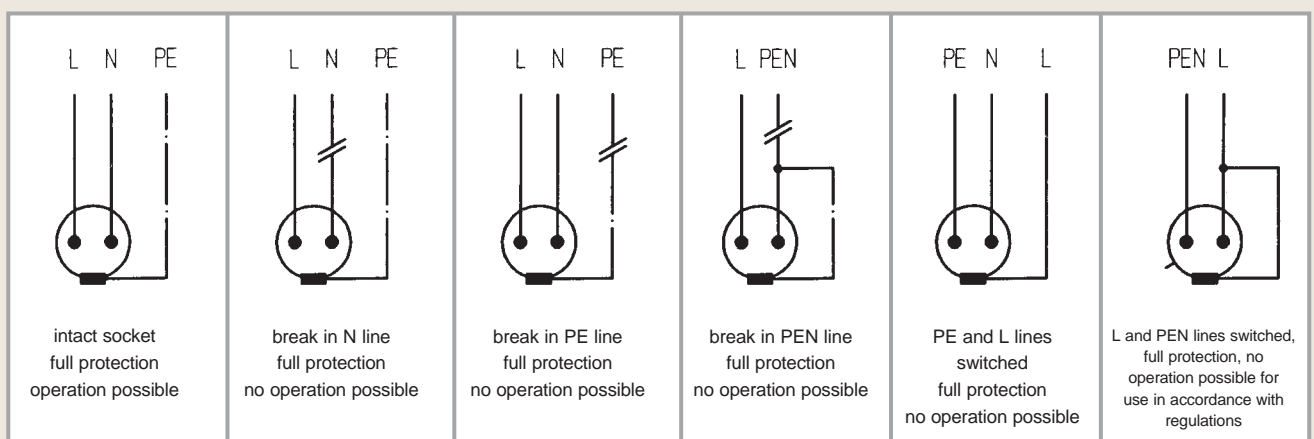

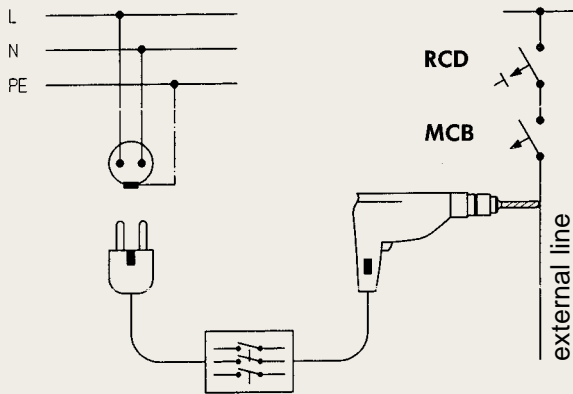

- drilling into external lines
- full protection through safety measures in the external line
- PRCD-S detects the external voltage on the protective earthing yet without interrupting the protective earthing connection, thus allowing the external voltage to be activated through its own upstream RCD and MCB safety devices

Use and Function

Specially designed for construction and assembly sites.

- IP 68 protection class
 - neither prolonged submersion in water nor extreme levels of dust exposure can negatively impact functionality, efficiency, or durability
 - long service life even when subjected to excessive strain
- aluminum injection molded housing
- suitable for direct connection with the feed cable of the electrical device (H07 RN-F 3G 2.5 mm2)
- can be implemented independently of whichever plug system is being used
- large, easy-to-use ON and OFF buttons
- additional optical switch position display
- undervoltage release
- extremely short trigger time
 - unit cannot be operated without personal protection if safety precautions are compulsory
 - plug types can be changed without needing to make a new purchase COST SAVINGS
 - simple and safe operation
 - operational status is easy to discern
 - prevention of uncontrolled restarting of machines after power returns
 - the user's protection level is heightened

Technical Data:

Rated voltage: 230 V/50 Hz	Nominal Current: 16 A	Protection Class: max. IP 68	Conductor Cross-Section: 1 mm ² to 2.5 mm ²
Nominal Fault Current: 10 or 30 mA	Ambient Temperature: -25° to 40° C with a daily mean value that does not exceed 35° C	Norms and Standards: - DIN VDE 0661 - DIN 40040 or DIN EN 60721	

— other cable lengths and further models on request —
subject to modification and errors

Aluminum Energy Columns





other standard
RAL colors
on request

Model	Height	Number	Output	Sockets	Fuse Protection	Residual Current	RCD Typ A Circuit Breaker I _{res}	Order No.
Type B	757 mm	1 CEE 5p. / 32 A / 400 V / 6 h 1 CEE 5p. / 16 A / 400 V / 6 h 2 earthing contact sockets 1 compressed air 1/2" 2 CAT6 network RJ45			1 MCB C-Char. 3p. / 16 A 1 MCB B-Char. 1p. / 16 A	1 RCD 4p. / 40 A / 30 mA		6AM593B001
Type C	1.040 mm	1 CEE 5p. / 32 A / 400 V / 6 h 2 CEE 5p. / 16 A / 400 V / 6 h 2 CEE 3p. / 16 A / 230 V / 6 h 3 earthing contact sockets 1 compressed air 1/2"			1 MCB C-Char. 3p. / 32 A 1 MCB C-Char. 3p. / 16 A 2 MCB B-Char. 1p. / 16 A 3 MCB B-Char. 1p. / 16 A	1 RCD 4p. / 63 A / 30 mA		6AM593C003

- other models on request / subject to modification and errors -



← The cover plate of each energy column is tightly secured with a rubber seal.

The feed cable enters the column through the base plate. This area houses the generously dimensioned energy-supply compartment, which ensures the quick and uncomplicated connection of the feed cable after removal of the front panel. →

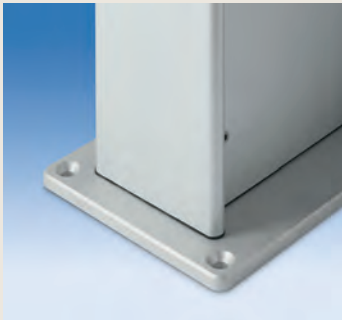

← The column profile and the base plate are tightly screwed together. The base plate is affixed with four M8 screws to the respective ground surface.

SPECIAL FEATURES:

- closed anodized and plastic-powder-coated aluminum profile with base and cover plates made of anodized and plastic-powder-coated aluminum → corrosion-resistant and weatherproof to ward against outside elements; long service life
- EPDM seals between the individual column sections → high protection class, up to max. IP 65; suitable for use in damp areas and outdoor sites
- timeless and premium-quality appearance → the columns make a good impression in representative areas as well, such as reception or office spaces
- available in different heights and models → individual models custom-tailored to each client's needs; 4-sided configurations also possible
- individual modular configurations with the highest possible safety thanks to compartmentalization → low-voltage sockets, extra-low-voltage sockets, network sockets, air, intercom systems, switches, etc.
- range of application → offices, reception areas, stand-alone solutions, access control, production areas, laboratories, etc.
- protection guards are externally accessible and situated safely behind transparent hinged windows → simple operation of the protection guards without opening the housing
- dimensions → Footprint: 250 x 180 mm
 Profile size: 200 x 120 mm
 Wall thickness: min. 2.5 mm

Plugs with Earthing Contact and CEE Plug Connectors – Industrial Models –

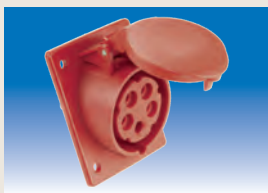

CEE Industrial Connector Systems

as per DIN VDE 0623 Part 1/EN 60309/IEC 60309



SPECIAL FEATURES:

Housing and Inserts

- breakproof and impact-resistant, highly resistant to wear and abrasion → long service life, even under demanding conditions **cost savings**
- high resistance to cold and hot temperatures → dimensionally stable and safe from -25° to +80°
- cadmium- and halogen-free → low impact on the environment
- very strong resistance to a large number of different chemicals → safe during use, even under extreme working conditions

Contacts

- all pins and connectors are nickel-plated → increased level of corrosion resistance, prevents pins and connectors from sticking

Terminal Screws

- easily accessible from one direction → convenient handling during the connection process
- safeguarded against accidental removal when open (ready-to-connect) → time savings

Time position of the earthing contact and color coding:

	4h	9h	6h	11h	7h	5h	12h	1h	10h	2h	3h	8h
Frequency [Hz]	50-60	50-60	50-60	60	50-60	50-60	50-60	-	100-300	over 300 to 500	50-60	
Voltage [V]	57/100 to 75/130	120/208 to 144/250	200/346 to 240/415	250/400 to 265/460	277/480 to 288/500	347/600 to 400/690		over 50	over 50	over 50	220/380 to 250/440 16+32 A	
5-pol. 3-pol.+N+PE												
Voltage [V]	100-130	200-250	380-415	440-460	480-500	600-690	voltage according to isolating transformer		over 50	over 50	380-440 only for 16+32 A	
4-pol. 3-pol.+PE												
Voltage [V]	100-130	380-415	200-250		480-500	277	voltage according to isolating transformer				over 50 to 250 direct current	over 250 direct current
3-pol. 2-pol.+PE												

View of the contact sockets as seen from the front side of the connector sockets.
63 A + 125 A plug connectors with pilot contact.

Position of auxiliary nose to earth nose for voltages up to 50 V and frequencies up to 500 Hz and color coding.:

	-	12h	4h	2h	3h	11h	10h
Frequency [Hz]	50-60	50-60	100-200	300	400	over 400 to 500	GS
Voltage [V]	20-25	40-50	40-50	to 50	to 50	to 50	to 50
2-pole							
3-pole							

View of the contact sockets as seen from the front side of the connector sockets.

Item Numbers

Industrial Connector Systems

110 V ~
50–60 HZ
4 h

230 V ~
50–60 HZ

400 V ~
50–60 HZ
6 h

500 V ~
50–60 HZ
7 h

> 50 V ~
100–300 HZ
10 h

> 50 V ~
301–500 HZ
2 h

Nominal Current / Ampere
Number of poles

Plugs
Connectors
Surface-Mounted Sockets (tilted)

S1113	S2213					3	16
S1114	S2214	S3814	S5014	S50110H	S5012H	4	16
		S3815				5	16
S1133	S2233					3	32
S1134	S2234	S3834	S5034	S50310H	S5032H	4	32
		S3835				5	32



S1163	S2263					3	63
S1164	S2264	S3864	S5064	S50610H	S5062H	4	63
		S3865				5	63
		S38X4	S50X4			3	125
		S38X5				4	125
						5	125

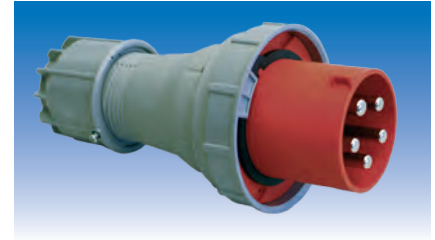

K1113	K2213					3	16
K1114	K2214	K3814	K5014	K50110H	K5012H	4	16
		K3815				5	16
K1133	K2233					3	32
K1134	K2234	K3834	K5034	K50310H	K5032H	4	32
		K3835				5	32

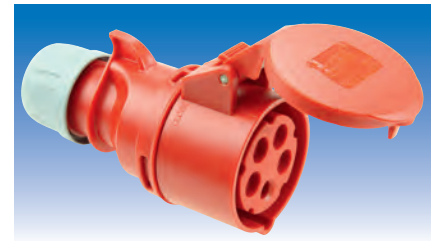

K1163	K2263					3	63
K1164	K2264	K3864	K5064	K50610H	K5062H	4	63
		K3865				5	63
		K38X4	K50X4			3	125
		K38X5				4	125
						5	125

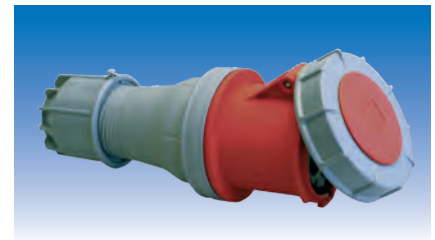

AD1113S	AD2213S					3	16
AD1114S	AD2214S	AD3814S	AD5014S	AD50110HS	AD5012HS	4	16
		AD3815S				5	16
AD1133S	AD2233S					3	32
AD1134S	AD2234S	AD3834S	AD5034S	AD50310HS	AD5032HS	4	32
		AD3835S				5	32

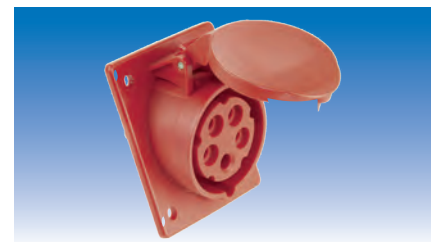

AD1163S	AD2263S					3	63
AD1164S	AD2264S	AD3864S	AD5064S	AD50610HS	AD5062HS	4	63
		AD3865S				5	63
		AD38X4S	AD50X4S			3	125
		AD38X5S				4	125
						5	125



– further models on request / subject to modification and errors –

Item Numbers

Industrial Connector Systems

110 V ~
50-60 HZ
4 h

230 V ~
50-60 HZ

400 V ~
50-60 HZ
6 h

500 V ~
50-60 HZ
7 h

>50 V ~
100-300 HZ
10 h

>50 V ~
301-500 HZ
2 h

Number of poles
Nominal Current, Amperes

Surface-Mounted Sockets (straight)
Surface-Mounted Plug Connectors
Wall Sockets

AD1113	AD2213					3	16
AD1114	AD2214	AD3814	AD5014	AD50110H	AD5012H	4	16
		AD3815				5	16
AD1133	AD2233					3	32
AD1134	AD2234	AD3834	AD5034	AD50310H	AD5032H	4	32
		AD3835				5	32

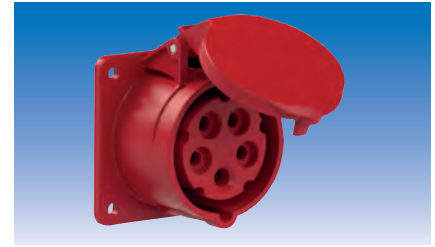

AD1163	AD2263					3	63
AD1164	AD2264	AD3864	AD5064			4	63
		AD3865				5	63
		AD38X4	AD50X4			3	125
		AD38X5				4	125
						5	125



straight version	AGS2213					3	16
	AGS2214	AGS3814	AGS5014			4	16
		AGS3815				5	16
	AGS2233					3	32
	AGS2234	AGS3834	AGS5034			4	32
		AGS3835				5	32



sloping design	ASS2263					3	63
	ASS2264	ASS3864	ASS5064			4	63
		ASS3865				5	63
		ASS38X4	ASS50X4			3	125
		ASS38X5				4	125
						5	125



WSD1113S	WSD2213					3	16
WSD1114S	WSD2214	WSD3814	WSD5014	WSD50110H	WSD5012H	4	16
		WSD3815				5	16
WSD1133	WSD2233					3	32
WSD1134	WSD2234	WSD3834	WSD5034	WSD50310H	WSD5032H	4	32
		WSD3835				5	32



	WSD2263					3	63
	WSD2264	WSD3864	WSD5064			4	63
		WSD3865				5	63
		WSD38X4	WSD50X4			3	125
		WSD38X5				4	125
						5	125



– further models on request / subject to modification and errors –

Item Numbers

24 V ~
50-60 HZ

42 V ~
50-60 HZ

Nominal Current-Ampere
Pole Number

Plug
Connector
Surface-Mounted Socket (tilted)
Surface-Mounted Socket (straight)
Wall Socket

	S2412		S4212			2	16
	S2413		S4213			3	16
	S2432		S4232			2	32
	S2433		S4233			3	32

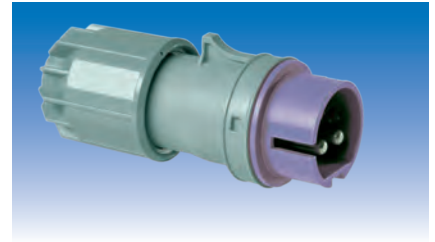

	K2412		K4212			2	16
	K2413		K4213			3	16
	K2432		K4232			2	32
	K2433		K4233			3	32



straight model	AD2412		AD4212			2	16
	AD2413		AD4213			3	16
	AD2432		AD4232			2	32
	AD2433		AD4233			3	32
tilted model	AD2412S		AD4212S			2	16
	AD2413S		AD4213S			3	16
	AD2432S		AD4232S			2	32
	AD2433S		AD4233S			3	32



	WSD2412		WSD4212			2	16
	WSD2413		WSD4213			3	16
	WSD2432		WSD4232			2	32
	WSD2433		WSD4233			3	32



400 V ~
50-60 HZ
6 h

Phase Inverter Plug

			PW3815			5	16
			PW3835			5	32



– further models on request / subject to modification and errors –



MODEL:

Solid rubber plug with earthing contact 3 pol. / 16 A / 230 V / black-blue

- complying with the standard DIN 49440/441
- with metric screw connection
- impact-resistant
- IP54 - splashproof
- for a cable diameter 6 - 14 mm
- flexible connection cross-section 3G1,0 / 3G2,5 mm²
- screwless quick locking system
- external strain relief

Order No.

SCH11/PG/BL/N



Solid rubber connector with earthing contact 3 pol. / 16 A / 230 V

- complying with the standard DIN 49440/441
- with metric screw connection
- with self-closing hinged lid
- impact-resistant
- IP54 - splashproof
- for a cable diameter 6 - 14 mm
- flexible connection cross-section 3G1,0 / 3G2,5 mm²
- screwless quick locking system
- external strain relief

SCH21/K/PG/BL/N



optional with LED

- optional with integrated voltage indicator (green LED lamp) (see small picture)

SCH21/K/PG/BL/LED

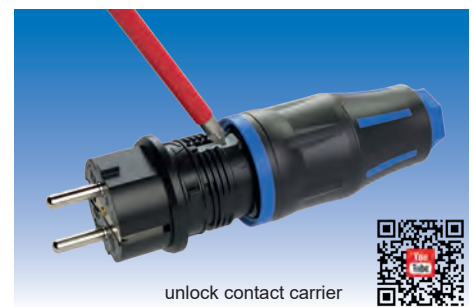

unlock contact carrier



Solid rubber tripple connector with earthing contact 3 pol. / 16 A / 230 V

- complying with the standard DIN 49440/441
- with metric screw connection
- with self-closing hinged lids
- with integrated voltage indicator (green LED lamp)
- impact-resistant
- IP44 - splashproof
- with separate connection compartment
- for a cable diameter 6-19 mm
- flexible connection cross-section 3G1,5 / 3G2,5 mm²
- screwless, centric strain relief
- customized models: equipped with flexible INDUSTRIEFLEX® 07 HT cable

SCH31/P



- with solid rubber earthed plug and 5 m INDUSTRIEFLEX® 07 HT 3G1,5 mm²
- with solid rubber earthed plug and 10 m INDUSTRIEFLEX® 07 HT 3G1,5 mm²
- with solid rubber earthed plug and 20 m INDUSTRIEFLEX® 07 HT 3G1,5 mm²

S5KD

S10KD

S20KD



– other models on request / subject to modification and errors –

Industrial Plugs and Sockets with Earthing Contact

2pol. + PE, 10/16 A, 250 V, as per DIN 49440 and 49441-2-AR1 (IEC 884) DIN VDE 0620h, CEE7/VII
2pol. + PE, 10/16 A, 250 V, SEV 1011

Order No.



Built-in socket

- with self-closing hinged lid



SCH51P

Wall-mounted socket (lower segment)



SCH61P

Wall-mounted socket

- no fig. – (SCH51P + SCH61P)



SCH71P

Cable entry from top **and** bottom!

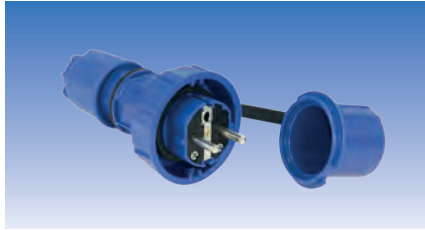

Plug with earthing contact, water-pressure-tight

- with lock ring and cap
- material PC/ABS
- DIN 49 443-R2
- protection class IP66/68

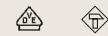

SCH11WDP



Socket with earthing contact, water-pressure-tight

- with cap
- material PC/ABS
- DIN 49 442-B
- protection class IP66/68

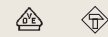

SCH21WDP

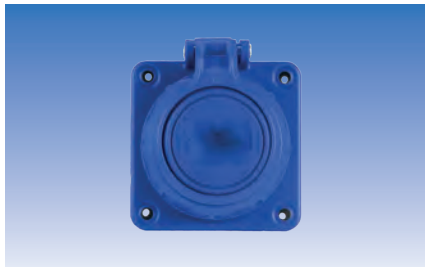

Built-in socket, water-pressure-tight

- with self-closing hinged lid
- material PC/ABS
- DIN 49 442
- protection class IP66/68



SCH51WDP

Industrial connection boxes



Connection box 3 pol. / 450 V / 17,5 A

- I-Box, 2 connections
- material PA 6.6, colour black
- dimensions 134 x Ø 27 mm
- cable diameter 7 - 13,5 mm
- protection class IP68

VB2M20

Connection box 5 pol. / 450 V / 17,5 A (no fig.)

- I-Box, 2 connections
- material PA 6.6, colour black
- dimensions 135 x Ø 35 mm
- cable diameter 7 - 13,5 mm
- protection class IP68

VB2M25

Connection box 3 pol. / 450 V / 17,5 A

- T-Box, 3 connections
- material PA 6.6, colour black
- dimensions 116 x 101 x Ø 34 mm
- cable diameter 7 - 13,5 mm
- protection class IP68

VB3M20II

– subject to modification and errors –

Special Cable Solutions



INDUSTRIEFLEX® 07 HT

Heavy-duty rubber special hose lines that are waterproof and heat-resistant and adhere to:

EN 50525-2-21

DIN VDE 0285-525-2-21

H07RN-F H07RN8-F H07BN4-F

TYPICAL FIELDS OF APPLICATION:

- construction and assembly sites
- steel and automobile industries
- heavy welding manufacturers
- chemical industry / Ex manufacturers (VDE 0165)
- municipal utilities, waterworks, and sewage treatment plants
- power plants and nuclear power stations

For use as per HD 516 / DIN VDE 0298

- in both dry and damp spaces
- for continuous implementation in outdoor areas
- in potentially explosive atmospheres (as per VDE 0165)
- in commercial and agricultural settings

SPECIAL FEATURES:

- cross-linked and compressed external sheathing material
- “closed” external sheath surface
- modified external sheath mixture
- silicon-free sheath and lead insulation
- tin-plated copper wires / inner leads
- depending on the cross-section, ultra-fine wires of either copper class 6 or copper class 5 (for details, see page 8.2)



- in engines or machines at construction sites
- in unpolluted water up to 10 meters deep and water temperature of 40° C in accordance with AD8 (e.g., for diving pumps); also water-resistant down to 50 meters in slightly polluted wastewater of industrial and domestic origin
- also designed to withstand high mechanical strain; durability is enhanced thanks to extremely tear-resistant qualities, which amounts to COST SAVINGS
- absorption of oils and chemicals is next to impossible
- resistant to UV, ozone, hydrolysis, and inclement weather; also flame-resistant, immediately self-extinguishing, infusible
- extremely flexible, even at low temperatures
- easy implementation in paint-related contexts (e.g., automotive industry); no coating effect or aggressive deposits (e.g., in electronics / circuit boards)
- no adverse interaction between copper and lead insulation material; no corrosion and no scaling of the connection points
- maximal flexibility for easy handling, even under challenging conditions, lower lead rupture, and therefore COST SAVINGS thanks to HIGH DURABILITY

– other models on request / subject to modification and errors –

Cross-Section in mm ²	Copper Class	Average Outside Diameter in mm	Order No.
2 x 1.00	6	8.2	SL07HT 210
3 G 1.00	6	9.1	SL07HT 310
4 G 1.00	6	9.6	SL07HT 410
5 G 1.00	5	11.6	SL07HT 510
2 x 1.50	6	9.1	SL07HT 215
3 G 1.50	6	9.8	SL07HT 315
4 G 1.50	6	11.3	SL07HT 415
5 G 1.50	5	11.9	SL07HT 515
7 G 1.50	5	15.7	SL07HT 715
12 G 1.50	5	18.5	SL07HT 1215
2 x 2.50	5	10.9	SL07HT 225
3 G 2.50	5	11.6	SL07HT 325
4 G 2.50	5	12.7	SL07HT 425
5 G 2.50	5	13.9	SL07HT 525
2 G 4.00	5	12.9	SL07HT 240
5 G 4.00	5	16.9	SL07HT 540
2 x 6.00	5	15.1	SL07HT 260
5 G 6.00	5	18.9	SL07HT 560
5 G 10.00	5	25.5	SL07HT 5100
5 G 16.00	5	28.9	SL07HT 5160

- other models on request; if desired also with imprinting (e.g., company name)
- presentation: drum or 100 m rings
- inside wiring up to 5 leads, color-coded
> 5-lead numbering

TECHNICAL DATA:

Nominal current: 450 V / 750 V
 Conductor temperature: up to +90°C
 Ambient temperature: up to +85°C
 up to -25°C (flexible) as per HD 22.4,
 also deployable down to -35°C

Test voltage: 2,500 V
 Flame resistance: DIN EN 60332-1-2
 Tensile load: max. 15 N/mm² conductor cross-section
 Cross-sections: up to max. 5 x 16 mm² possible

Current load of a 1.5 mm² cable in connection to temperature

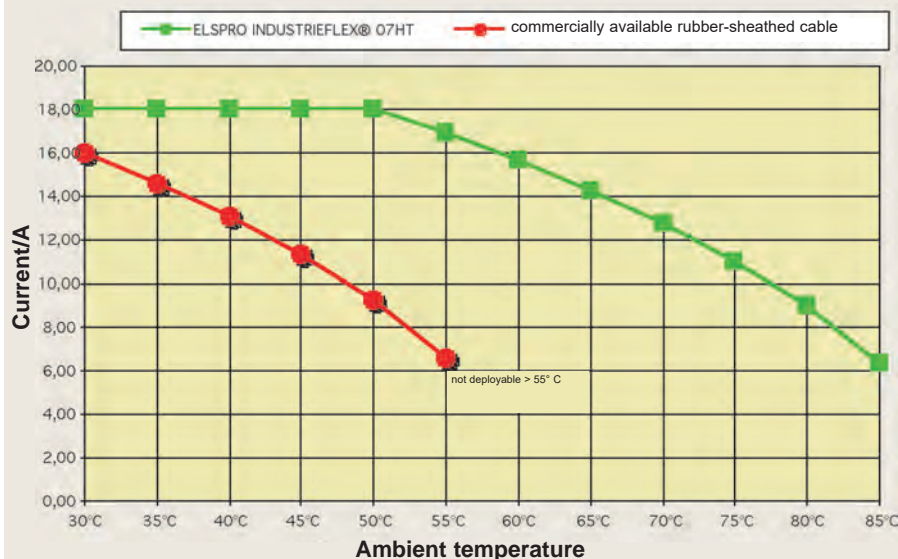

The adjacent chart presents the values for standard cables subjected to ambient temperatures of up to 55° C (H07RN-F) as compared to INDUSTRIEFLEX® 07 HT cables.

PLEASE NOTE:

The values displayed do not apply to feed lines attached to house or hand units. In order to avoid accidents caused by too high of temperatures along the external sheath, the latter may only be operated with a current load capacity in accordance with VDE 0298, chart 11, columns 3 and 4, regardless of the respective ambient temperature.

Please take the conditions of your specific operating situation into account!

In order to ensure that customers receive consistently high quality when using cables under the name INDUSTRIEFLEX®, protection is provided through the German Patent Office under the number 2043633.

Extension Cables with INDUSTRIEFLEX® 07 HT

Models:

- any desired length
- all customary connection systems
- partially customized solutions also possible
- multipole connector systems in all sizes
- other cable types on request
- K2 marking



SPECIAL FEATURES:

- ULTRA-FINE copper (see page 8.2) → considerably lower chance of conductor breakage; easy handling even under difficult conditions
- high-quality plug connectors with earthing contact displaying VDE, hammer, and drip symbols → use in indoor and outdoor areas, such as in the open air, in damp rooms, and at construction and assembly sites
- CEE plug connectors made of polyamide 6, with nickel-plated contacts → long service life even under extreme conditions, **COST SAVINGS**
- made and tested by specialized professionals → cables ready to use immediately

Technical data and other specifics pertaining to the INDUSTRIEFLEX® HT cable can be found on pages 8.1 + 8.2

Plug	Length	Connector	Order No.	Version	Order No.
earthing contact	5 m 10 m 20 m	earthing contact	S5K S10K S20K	with triple connector	S5KD S10KD S20KD
CEE 230V/3pol. 16A	5 m 10 m 20 m	CEE 230V/3pol. 16A	CS5K2213 CS10K2213 CS20K2213		
CEE 400V/5pol. 16A	5 m 10 m 20 m	CEE 400V/5pol. 16A	CS5K1 CS10K1 CS20K1	with phase inverter plug on request	
32A	5 m 10 m 20 m	32A	CS5K3 CS10K3 CS20K3	with phase inverter plug on request	
63A	5 m 10 m 20 m	63A	CS5K6 CS10K6 CS20K6		

– other models on request / subject to modification and errors –

Selection of our cables always adheres to the VDE regulations valid at the present time.

Device Connecting Cables INDUSTRIEFLEX® 07 HT

For portable devices, electric tools, handheld units, etc.

RANGE OF APPLICATION:

- construction and assembly sites
- industry, trade, and agriculture

- special rubber cable
- signal color yellow
- tin-plated inside wiring
- internal marker threads
- type code printed on external sheath



MODEL:

- with molded contour plug and 2-lead cable
- with molded earthed plug and 3-lead cable
- sheath has been removed from the end, while leads have been insulated and fitted with end ferrules

SPECIAL FEATURES:

- ergonomic and anti-slip plug form → minimized installation time - COST SAVINGS
- ready to use; featuring extended protective earthing conductor (3-lead) → easy handling, even under rough conditions
- ultra-fine copper wire (highly flexible)

Technical data and other specifics pertaining to the INDUSTRIEFLEX® HT cable can be found on pages 8.1 + 8.2

Length	Cross-Section	Outside Ø ca.	Plug Type	Order No.
2 m 3 m 5 m 10 m	2 x 1.0 mm ²	8.2 mm	contour plug	210 M2 SL07 210 M3 SL07 210 M5 SL07 210 M10 SL07
2 m 3 m 5 m 10 m	2 x 1.5 mm ²	9.1 mm	contour plug	215 M2 SL07 215 M3 SL07 215 M5 SL07 215 M10 SL07
2 m 3 m 5 m 10 m	3 G 1.5 mm ²	9.8 mm	earthed plug	315 M2 SL07 315 M3 SL07 315 M5 SL07 315 M10 SL07

– other models on request / subject to modification and errors –

Device Connecting Cables INDUSTRIEFLEX® 05 HT

For hand-operated electrical equipment

- special rubber cable
- signal color yellow
- tin-plated inside wiring
- internal marker threads
- type code printed on external sheath



* with small outside diameter *

RANGE OF APPLICATION:

- permissible at construction and assembly sites for up to 4 m in length, provided that no other supplementary DIN/VDE regulations apply (e.g., 0740)

MODEL:

- with molded contour plug and 2-lead cable
- with molded earthed plug and 3-lead cable
- sheath has been removed from the end, while leads have been insulated and fitted with end ferrules

SPECIAL FEATURES:

- small outside diameter → effortless installation, even in the case of small device entry
- ergonomic and anti-slip plug form → easy plugging and unplugging
- ready to use; featuring extended protective earthing conductor (3-lead) → minimized installation time - COST SAVINGS
- ultra-fine copper wire (highly flexible) → easy handling, even under rough conditions

Technical data and other specifics pertaining to the INDUSTRIEFLEX® 05 HT cable can be found on page 8.8

Length	Cross-Section	Exterior Ø ca.	Plug Type	Order No.
4 m	2 x 1.0 mm ²	6.8 mm	contour plug	210M4IF
4 m	3 G 1.0 mm ²	7.2 mm	earthed plug	310M4IF

– other models on request / subject to modification and errors –

Device Connecting Cables with Your Company Name

INDUSTRIEFLEX® 07 HT and INDUSTRIEFLEX® 05 HT

- special rubber cable
- signal color yellow
- tin-plated inside wiring
- internal marker threads
- type code printed on external sheath



MODEL:

- with molded contour plug and 2-lead cable
- with molded earthed plug and 3-lead cable
- sheath has been removed from the end, while leads have been insulated and fitted with end ferrules

SPECIAL FEATURES:

- with imprinting using state-of-the art technology, e.g., company name, department, telephone and fax numbers → clear recognition of company property; assignment of devices according to department; advertising
- special ink → imprint is smudgeproof, even when in contact with chemicals (oils, solvents, gasoline, etc.)
- ultra-fine copper wire (highly flexible) → all handheld units can be marked
- delivery available at a minimum purchase of 20 cables per model → easy handling, even under rough conditions

INDUSTRIEFLEX® 07 HT Technical data and further special features on pages 8.1 and 8.2

Length	Cross-Section	Outside Ø ca.	Plug Type	Order No.
3 m	2 x 1.0 mm ²	8.2 mm	contour plug	210 M3 SL07/A
5 m				210 M5 SL07/A
3 m	2 x 1.5 mm ²	9.1 mm	contour plug	215 M3 SL07/A
5 m				215 M5 SL07/A
3 m	3 G 1.5 mm ²	9.8 mm	earthed plug	315 M3 SL07/A
5 m				315 M5 SL07/A

INDUSTRIEFLEX® 05 HT Technical data and further special features on pages 8.8

4 m	2 x 1.0 mm ²	6.8 mm	contour plug	210M4IF/A
4 m	3 G 1.0 mm ²	7.2 mm	earthed plug	310M4IF/A

– other models on request / subject to modification and errors –

Technical data for the connecting cables (page 8.6) INDUSTRIEFLEX® 05 HT

Special rubber hose line with internal marker threads and type code printed on external sheath;
color: yellow

Regulations:	DIN/VDE 0282-1/-2/-4/0293-308/0295/0298-3	
Nominal voltage:	U _o /U = 300/500 V	SL05 HT
Alternating current test voltage:	U _o /U = 2000 V	SL05 HT

Operating temperature:	max. 60°C -40°C (retains full functionality) -25°C, working with cable possible
Combustion behavior and self-extinguishment:	DIN VDE 0482-332-1/-2 SL05 HT

Conductors:	copper, flexible, tin-plated
Bending radii (in open wiring contexts):	3d ≤ 8mm outside diameter 4d > 8mm ≤ 12mm, 5d > 12 mm
Tensile load:	max. 15 N/mm ²

SPECIAL FEATURES:

- cross-linked and compressed external sheathing material → also designed to withstand high mechanical strain, enormously TEAR-RESISTANT, long service life
- “closed” external sheath surface → absorption of oils and chemicals is next to impossible; extremely high durability
- modified external sheath mixture → resistant to UV, ozone, hydrolysis, and inclement weather; also flame-resistant, immediately self-extinguishing, infusible
→ extremely flexible, even at low temperatures
- silicon-free sheath and lead insulation → easy implementation in paint-related contexts (e.g., automotive industry); no coating effect or aggressive deposits (e.g., in electronics / circuit boards)
- tin-plated inside wiring → no adverse interaction between copper and lead insulation material
→ no corrosion and no scaling of the connection points

TYPICAL FIELDS OF APPLICATION:

- construction and assembly sites
- steel and automobile industries
- municipal utilities, waterworks, and sewage treatment plants
- power plants and nuclear power stations

In order to ensure that customers receive consistently high quality when using cables under the name INDUSTRIEFLEX®, protection is provided through the German Patent Office under the number 2043633.

– other models on request / subject to modification and errors –

ELSPRO-FLEX® G 05 (from 2 x 0.75 - 5 G 1.00 mm²)

ELSPRO-FLEX® G 07 (from 2 x 1.50 - 5 G16.00 mm²)

Special hose line with modified polyurethane sheath and EPR lead insulation

- cable certified by VDE and HAR
- tin-plated CU conductor
- signal color yellow
- type code printed on external sheath

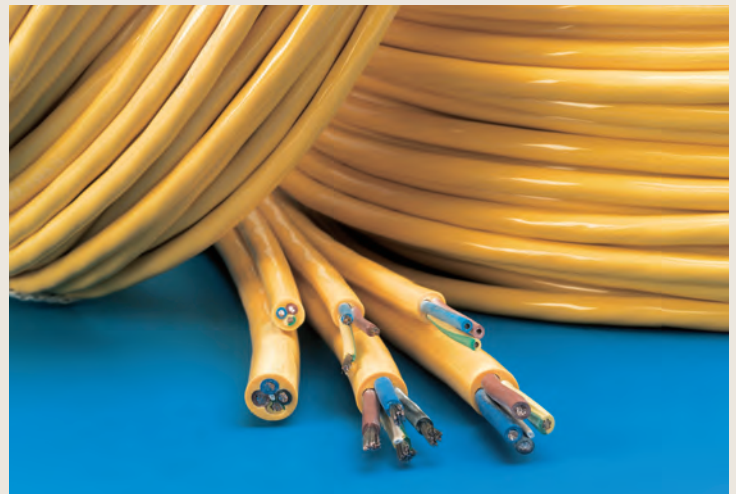

SPECIAL FEATURES:

- **ULTRA-FINE copper wire (class 6), highly flexible** → significantly lower chance of "lead rupture"; easy handling, even under rough conditions
- halogen-free → no harmful halogens released (e.g., chlorine/hydrochloric acid)
- silicon-free sheath and lead insulation → easy implementation in paint-related contexts; no coating effect or aggressive deposits
- withstands high mechanical loads → long service life, fewer production losses **COST SAVINGS**
- resistant to grease, organic and inorganic oils (as per VDE 0472/803A) → next to no "swelling" of the cable
- outstanding abrasion resistance → implementable under high shear and abrasion loads
- excellent resistance to tear and high notch tensile strength → any damage to the sheath remains "localized"
- high radiation resistance → can be used in various contexts, e.g., with radiation equipment, fusion research facilities, particle accelerators, etc.

Outside Diameter in mm		Cross-Section in mm ²	Order No.
Mean Value	Max.		
7.2	8.1	3 G 0.75	G05 3075
7.8	8.8	4 G 0.75	G05 4075
8.8	9.8	5 G 0.75	G05 5075
7.1	8.0	2 x 1.00	G05 210
7.5	8.5	3 G 1.00	G05 310
7.1	9.3	4 G 1.00	G05 410
8.7	9.8	2 x 1.50	G07 215
10.3	11.6	2 x 2.50	G07 225*
9.2	10.4	3 G 1.50	G07 315
11.0	12.4	3 G 2.50	G07 325*
10.2	11.6	4 G 1.50	G07 415
11.1	12.7	5 G 1.50	G07 515*
13.7	15.3	5 G 2.50	G07 525*
16.0	17.9	5 G 4.00	G07 540*
17.9	20.0	5 G 6.00	G07 560*
13.0		7 G 1.50	G07 715*

Inside wiring up to 5 leads, color-coded > 5-lead numbering

* Model with copper class 5

– other models on request / subject to modification and errors –

REGULATIONS: DIN VDE 0282 (Part 10)

EXTERIOR SHEATH:

- modified polyurethane
- color: yellow

VOLTAGES:

Nominal voltage:	$U_0/U = 300/500V$	G05
Nominal voltage:	$U_0/U = 450/750V$	G07
Operating voltage:	$U_0/U = 330/570V$	G05
Operating voltage:	$U_0/U = 500/865V$	G07
Alternating current test voltage:	3000V	

TEMPERATURES:

during operation (conductor temperature)	+ 90° C
in the case of a short circuit	+ 200° C
lowest working temperature, flexible	- 35° C
lowest working temperature, resting	- 45° C

BENDING RADII:

$d \leq 8 \text{ mm}$	$= 2d$
$d \text{ 8-12 mm}$	$= 3d$
$d > 12 \text{ mm}$	$= 4d$

INSIDE WIRING:

- ULTRA-FINE-WIRED,
tin-plated copper conductor (class 6 / DIN/VDE 0295 / IEC 228)
- special EPR insulation in accordance with DIN/VDE 0207T20

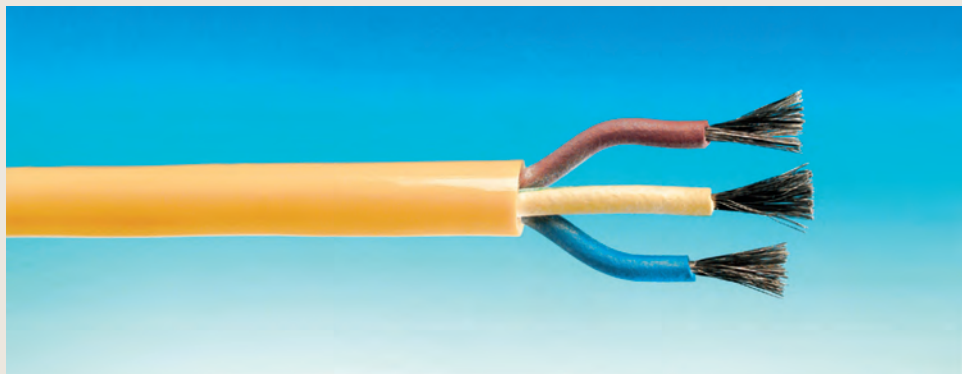

Skin contact should be avoided when the cable is used under high-temperature conditions.

For use in areas where

- hot components are touched
- “heavy” sweating occurs, beads of sweat appear
- thermal radiation is present
- there is exposure to open fire
(e.g., steel production and processing)

please use our INDUSTRIEFLEX® cables (catalog pages 8.1-8.8) or
ELSPRO-FLEX® THERM-MF cables (catalog pages 8.17) instead!

Polyurethane Extension Cables ELSPRO-FLEX® G07

MODELS:

- all customary connection systems
- partially customized solutions also possible
- any desired length
- K2 marking



SPECIAL FEATURES:

- *ULTRA-FINE* copper wire (highly flexible) → significantly lower chance of “lead rupture”; easy handling, even under rough conditions
- high-quality plug connectors with earthing contact displaying VDE, hammer, and drip symbols → use in indoor and outdoor areas, such as in the open air, in damp rooms, and at construction and assembly sites
- CEE plug connectors made of polyamide 6, with nickel-plated contacts → long service life, even under extreme conditions, **COST SAVINGS**
- made and tested by specialized professionals → cables ready to use immediately
- largely UV- and ozone-resistant → longer service life in outdoor areas

Technical data and other specifics pertaining to the ELSPRO-FLEX® G cable can be found on pages 8.9 / 8.10

Plug	Length	Connector	Order No.	Version	Order No.
earthed plug	5 m 10 m 20 m	earthed plug	S5KG S10KG S20KG	with triple connector with earthing contact	S5KDG S10KDG S20KDG
CEE 230V/3pol 16A	5 m 10 m 20 m	CEE 230V/3pol 16A	CS5K2213G CS10K2213G CS20K2213G		
CEE 400V/5pol 16A	5 m 10 m 20 m	CEE 400V/5pol 16A	CS5K1G CS10K1G CS20K1G	with phase inverter plug on request	
32A	5 m 10 m 20 m	32A	CS5K3G CS10K3G CS20K3G	with phase inverter plug on request	

– other models on request / subject to modification and errors –

Selection of our cables always adheres to the VDE regulations valid at the present time.

Polyurethane Device Connecting Cables ELSPRO-FLEX® G05/G07

Special hose line with modified polyurethane sheath and EPR lead insulation

RANGE OF APPLICATION:

- construction and assembly sites
- industry, trade, and agriculture
- cable certified by VDE and HAR
- tin-plated CU conductor
- signal color yellow
- type code printed on external sheath

MODEL:

- with molded contour plug and 2-lead cable
- with molded earthed plug and 3-lead cable
- sheath has been removed from the end, while leads have been insulated and fitted with end ferrules



SPECIAL FEATURES:

- ULTRA-FINE copper (highly flexible) → significantly lower chance of “lead rupture”; easy handling, even under rough conditions
- ergonomic and anti-slip plug form → easy plugging and unplugging
- ready to use; featuring extended protective earthing conductor (3-lead) → COST SAVINGS THANKS TO MINIMIZED INSTALLATION TIME
- largely UV- and ozone-resistant → longer service life in outdoor areas

Technical data and other specifics pertaining to the ELSPRO-FLEX® G cable can be found on pages 8.9 + 8.10

Length	Cross-Section	Outside Ø ca.	Plug Type	Order No.
3 m 5 m	2 x 1.0 mm ² 2 x 1.0 mm ²	7.1 mm	contour plug	210 M3 G05 210 M5 G05
3 m 5 m	2 x 1.5 mm ² 2 x 1.5 mm ²	8.7 mm	contour plug	215 M3 G07 215 M5 G07
3 m 5 m	3 G 1.5 mm ² 3 G 1.5 mm ²	9.2 mm	earthed plug	315 M3 G07 315 M5 G07

– other models on request / subject to modification and errors –



- **color of exterior sheath: orange or pink**
(depending on cross section)
- withstands high mechanical loads, features abrasion resistance
- flexible
- oil- and acid-resistant
(oil resistance as per VDE 0472 T 803)
- silicone- and halogen-free
- high resistance to ageing (even when subject to continuous use)
- will not become brittle or hardened prematurely
- **infusible**

SPECIAL FEATURES:

- high mechanical strength
- abrasion- and tear-resistant
- strong resistance to chemicals
- halogen-free
- enhanced flexibility
- **high resistance to ageing**
- in most fields of application, service life is extended significantly; in most cases no extra protective measures are needed - **COST SAVINGS**
- low degree of exterior sheath damage
- implementation even under challenging conditions: oils, grease, lyes, diverse chemical substances - **in certain cases a trial run may be advisable -**
- additional safety in the case of fire
- easy handling
- will not become brittle or hardened prematurely; extended service life (even under continuous use) **COST SAVINGS**

– other models on request / subject to modification and errors –

Cross-Section in mm ²	Approx. Outside Diameter in mm	Approx. Weight in kg/km	Order No.
2 x 0.75	7.0	70.0	HBFL2075E
3 G 0.75	7.5	80.0	HBFL3075E
4 G 0.75	8.5	100.0	HBFL4075E
5 G 0.75	9.0	130.0	HBFL5075E
7 G 0.75	10.5	160.0	HBFL7075E
12 G 0.75	on request	on request	HBFL12075E
3 G 1.00	8.0	100.0	HBFL310E
2 x 1.50	8.0	90.0	HBFL215E
3 G 1.50	9.0	130.0	HBFL315E
4 G 1.50	10.0	150.0	HBFL415E
5 G 1.50	11.0	190.0	HBFL515E
7 G 1.50	13.0	240.0	HBFL715E
12 G 1.50	17.0	430.0	HBFL1215E
25 G 1.50	24.0	770.0	HBFL2515E
3 G 2.50	11.0	190.0	HBFL325E
4 G 2.50	12.0	230.0	HBFL425E
5 G 2.50	13.0	290.0	HBFL525E
5 G 4.00	on request	on request	HBFL540E
5 G 6.00	17.0	530.0	HBFL560E
5 G 16.00	25.5	1,300.0	HBFL5160E

Presentation: 100 m rings or drum; delivery by arrangement

Inside wiring up to 5 leads, color-coded

> 5-lead numbering

TECHNICAL DATA:

Litz wire:	fine, tin-plated copper VDE 0295 class 5, IEC 60228 class 5, HD 383, lead insulation made of cross-linked polymer compound (HI 1)
Bending radius:	≥ 4d (fixed installation) ≥ 5d (flexible use) DIN VDE 0298 / T3
Temperature range:	-25°C to +135°C, 1-2 hrs.: +190°C, 2-3 min.: up to +600°C
Nominal voltage:	$U_0 / U / U_{max} = 300 / 500 / 550$ V
Test voltage:	2,000 V AC
External sheath:	cross-linked polymer compound (VDE 0207/HM 1), oil-resistant (VDE 0472 T 803)
Halogen-free:	EN 50267-2-1 / EN 60684-2
Non-corrosive:	EN 50267-2-2
Ecologically sound:	EN 50305-9.2
Flame-retardant and self-extinguishing:	EN 60332-2-1

– other models on request / subject to modification and errors –



The ELSPRO-FLEX® THERM-MF cable is excellently suited for all thermal areas within industrial contexts, where conventional silicone cables cannot be used (or only conditionally) due to their inability to handle high mechanical loads.

SPECIAL FEATURES:

- high mechanical strength
- abrasion- and tear-resistant
- strong resistance to chemicals
- high flash point
- halogen-free
- enhanced flexibility
- in most fields of application, service life is extended significantly; in most cases no extra protective measures are needed - **COST SAVINGS**
- low degree of exterior sheath damage
- implementation even under challenging conditions: oils, grease, lyes, diverse chemical substances - **in certain cases a trial run may be advisable -**
- in the case of fire, the charred exterior sheath provides an added insulating effect (safety aspect)
- additional safety in the case of fire
- easy handling

TECHNICAL DATA:

Litz wire:	fine, tin-plated copper wire VDE 0295 class 5/CEI20-29C5 lead insulation EI 2 VDE 0207 T20 (notch-resistant)
Bending radius under dynamic use:	15 d
Temperature range:	- 50°C to at least +180°C, even higher for short periods
Nominal voltage:	450/750 V
Test voltage:	2,500 V AC
External sheath:	mechanically resistant and notch-resistant special black silicone mixture 2GM/VDE 0207 T21
Halogen-free:	IEC 754-1 and VDE 0472 T813/IEC 754-2
Breakdown voltage:	20 KV/mm

– other models on request / subject to modification and errors –

Cross-Section in mm ²	Outside Diameter in mm		Order No.
	Mean Value	+/-	
2 x 0.75	6.4	0.2	MF2075
3 G 0.75	6.9	0.2	MF3075
4 G 0.75	7.6	0.2	MF4075
5 G 0.75	8.5	0.2	MF5075
7 G 0.75	9.2	0.2	MF7075
3 G 1.00	7.1	0.2	MF310
2 x 1.50	8.0	0.2	MF215
3 G 1.50	8.4	0.2	MF315
4 G 1.50	9.5	0.2	MF415
5 G 1.50	10.4	0.2	MF515
7 G 1.50	11.3	0.3	MF715
12 G 1.50	14.0	0.3	MF1215
16 G 1.50	17.1	0.4	MF1615
25 G 1.50	19.9	0.4	MF2515
3 G 2.50	9.8	0.2	MF325
4 G 2.50	11.1	0.3	MF425
5 G 2.50	12.4	0.3	MF525
5 G 4.00	14.0	0.3	MF540
5 G 6.00	16.6	0.4	MF560

Inside wiring up to 5 leads, color-coded
> 5-lead numbering

The designation MF stands for *heightened mechanical strength* and *stronger tear resistance*.

Presentation: 100 m rings or drum

– other models on request / subject to modification and errors –

Special Control Cable with Bearer Organs

FIELDS OF APPLICATION:

- crane and conveyor systems
- elevators and pendant control stations
- high-bay warehouse and pit construction
- *indoors and outdoors*

CONDUCTOR:

- bare ultra-fine copper litz wire

LEAD MARKING:

- single-color and consecutive numbering
- with green/yellow protective earthing conductor

OUTER SHEATH:

- special plastic
- cold-resistant, weatherproof, notch ductile, abrasion-resistant

SHEATH COLOR:

- signal colour yellow (or black on request)

TEMPERATURE RANGE:

- from -30°C to +70°C

BENDING RADIUS:

- with alternate bending 12 x D

PACKAGING:

- ring ware in any desired length (full meters only)
- longer lengths on drums

BESONDERHEITEN:

- 2 galvanized, plastic-coated steel cords are laterally
- 140 kp breaking load per cord



NOMINAL VOLTAGE: U_o/U 300/500 volt

TEST VOLTAGE: 3000 volt

- no need to fasten separate cords - TIME SAVINGS
- a considerably higher tensile load and almost no axial distortions prolong service life - COST SAVINGS

Cross-Section	Outside Ø (with bearer organs) ca.	Order No.
12 x 1.00 mm ²	15.0 (27.0) mm	SLSD1210
18 x 1.00 mm ²	17.0 (32.0) mm	SLSD1810
25 x 1.00 mm ²	21.0 (36.0) mm	SLSD2510
8 x 1.50 mm ²	15.0 (27.0) mm	SLSD0815
12 x 1.50 mm ²	16.5 (31.5) mm	SLSD1215
14 x 1.50 mm ²	17.6 (33.8) mm	SLSD1415
20 x 1.50 mm ²	21.0 (36.0) mm	SLSD2015
25 x 1.50 mm ²	23.1 (38.3) mm	SLSD2515

– other models on request / subject to modification and errors –

FIELDS OF APPLICATION:

- tambour doors, hydraulic ramps, electrical tools, portable equipment, etc.
- *indoors and outdoors*

Special hose line with modified polyurethane sheath

- signal color orange
- type code printed on external sheath



NOMINAL VOLTAGE:

- WL 05 U_o/U = 300/500 V
- WL 07 U_o/U = 450/750 V

OPERATING VOLTAGE:

- WL 05 U_o/U = 330/570 V
- WL 07 U_o/U = 500/865 V

TEMPERATURE RANGE:

- flexible -30°C / +90°C
 (conductor temperature)

SPECIAL FEATURES:

- custom-tailored to your needs starting at just 3 cables → no need to store large amounts of material
 - block lengths, extended lengths, and stretched ends can be adapted individually → optimized use during each application
 - extremely high restoring force thanks to state-of-the-art winding technology → long-term restorative effect
 - sheath withstands high mechanical loads and is notch ductile and abrasion-resistant → long service life, fewer production losses
 - resistant to grease, organic and inorganic oils → next to no “swelling” of the cable
- COST SAVINGS**

SEVERAL EXAMPLES: (with both ends straight, each 20 cm in length)

Cross-Section	Block Length	Extended Length	Order No.
2 x 1.0 mm ²	80 cm	320 cm	WL08210
	120 cm	480 cm	WL12210
	260 cm	1040 cm	WL26210
2 x 1.5 mm ²	80 cm	320 cm	WL08215
	120 cm	480 cm	WL12215
	260 cm	1040 cm	WL26215
3 G 1.5 mm ²	80 cm	320 cm	WL08315
	120 cm	480 cm	WL12315
	260 cm	1040 cm	WL26315
5 G 1.0 mm ²	80 cm	320 cm	WL08510
	120 cm	480 cm	WL12510
	260 cm	1040 cm	WL26510
5 G 1.5 mm ²	80 cm	320 cm	WL08515
	120 cm	480 cm	WL12515
	260 cm	1040 cm	WL26515

– other models on request / subject to modification and errors –

ELSPRO Equipotential Bonding Cable

This equipotential bonding cable has been developed to ensure a safe connection under inclement conditions.

The equipotential bonding cables are available as customized models and also offered as models ready for self-customization.

MODELS:

- ground clamp 200 A, with strong string
- cable lug for M8 screw

TECHNICAL DATA:

- operating voltage: 1,000 V
- alternating current test voltage: 3,500 V
- cadmium- and CFC-free
- conductivity resistance as per DIN VDE 0295, IEC 60228

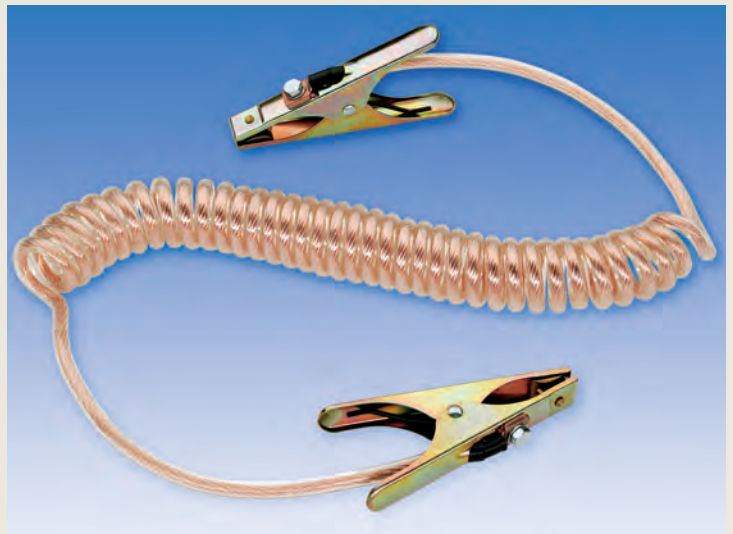

Customized cables (other models available on request):

Cross-Section	Max. Extended Length*	Cable Configuration		Order No.
		Beginning	End	
1 x 6.0 mm ²	4.0 m	earthing pliers cable lug cable lug	earthing pliers earthing pliers cable lug	WLP30EE6 WLP30EK6 WLP30KK6
	5.0 m	earthing pliers cable lug cable lug	earthing pliers earthing pliers cable lug	WLP50EE6 WLP50EK6 WLP50KK6

Cables with straight ends for self-customization (other models available on request):

Cross-Section	Max. Extended Length*	Cable Configuration		Order No.
		Beginning	End	
1 x 6.0 mm ²	4.0 m	_____	_____	WLP30/6
	5.0 m	_____	_____	WLP50/6
1 x 16.0 mm ²	4.0 m	_____	_____	WLP30/16
	6.0 m	_____	_____	WLP60/16/400
1 x 25.0 mm ²	3.0 m	_____	_____	WLP30/25
	5.0 m	_____	_____	WLP50/25

* the predefined maximum length should not be exceeded

SPECIAL FEATURES:

- strand structure: ultra-fine class 6 → considerably lower chance of conductor breakage
- transparent exterior sheath made of polyether polyurethane → unbreakable and impact-resistant, leading to a longer service life, COST SAVINGS
- resistant to oil and seawater; largely resistant to acid, lye, and solvents → next to no "swelling" of the cable
- halogen-free → no harmful halogens released (e.g., chlorine/hydrochloric acid)
- high restoring force → long-term restorative effect
- temperature range: -40°C to 80°C → broad temperature range for various application areas

– other models on request / subject to modification and errors –

Cable and Hose Bridge Systems Lightning Protection Bridges Cable Covers

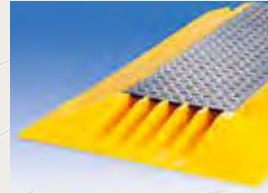

Types 5.1 and 5.0

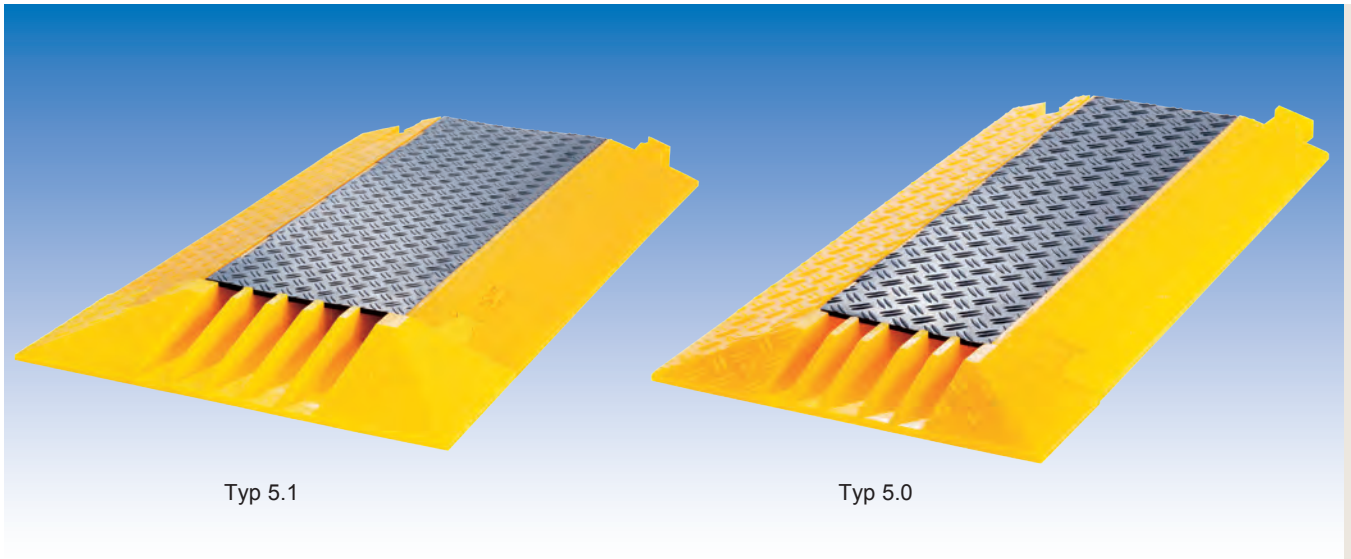

ELSPRO cable bridge systems

lend order and safety to temporary cable routing situations. They provide optimal protection against outside damage at cable crossings and prevent accidents. Systems engineering refined down to the last detail has been proven through many years of practical experience.

SPECIAL FEATURES:

- easy assembly thanks to modular connection system
- easily extendible and upgradable
- can be extended endlessly
- good fit on uneven ground
- slip- and abrasion-resistant
- temperature- and weatherproof

Material:

- cast, modified polyurethane elastomer

Suitable for:

- electrical, gas, water, compressed-air, and hydraulic cables

Areas of Application:

- streets, construction sites, trade fairs
- airports, harbors, industrial sites
- amusement parks, traveling shows
- military, disaster relief
- film, television, radio
- sports fields or arenas

– other models on request / subject to modification and errors –

Type 5.1

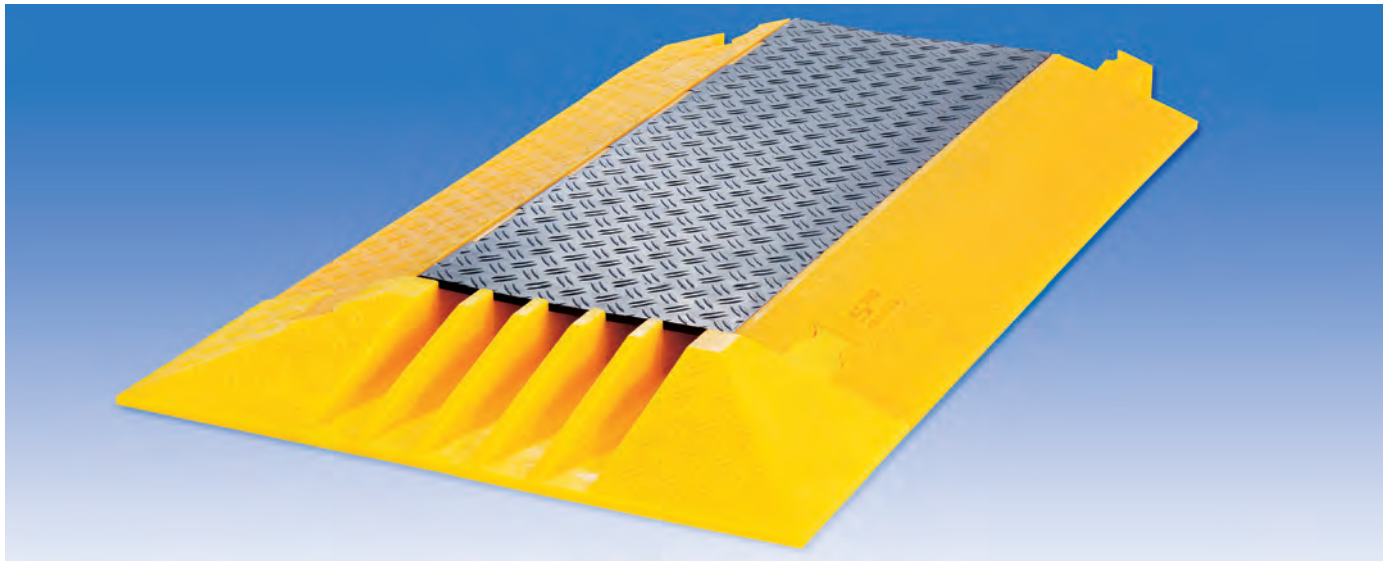

“Canale Grande”

Featuring 5 cable channels for lines with an outside diameter of up to 50 mm, Type 5.1 has plenty of capacity for large-scale projects that need temporary energy supply at professional standards.

- diverse range of application areas
- especially quick and simple assembly
- Stolperfallen werden entschärft

Technical Data:

- 5 passage channels, 50 x 50 mm each
- material: hot-cast polyurethane, subsequently annealed, temperature-resistant up to 80°C
- non-slip surfaces with corrugated structure
- body color: traffic yellow; cover color: black
- surface resistance: 1012 ohm (109 antistatic)
- dielectric strength: 15 kV/mm

Description	Dimensions (L x W x H)	Weight	Gradient Angle	Order No.
Bridge piece 5.1	1000 x 750 x 70 mm	32.6 kg	ca. 15°	5.1
End piece 5.1	300 x 750 x 70 mm	7.0 kg	ca. 15°	5.1 E
Bridge piece 5.1 antistatic	1000 x 750 x 70 mm	32.6 kg	ca. 15°	5.1 X
End piece 5.1 antistatic	300 x 750 x 70 mm	7.0 kg	ca. 15°	5.1 E X



– other models on request / subject to modification and errors –

ELSPRO Cable Bridges for Temporary Mobile Energy Supply Type 5.1

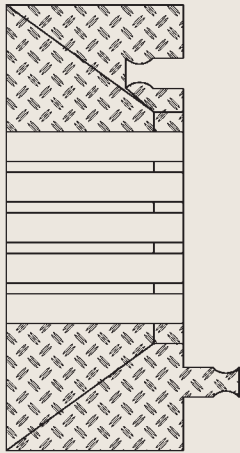

Length: 300 mm
Width: 750 mm
Height: 70 mm
Weight: 7.0 kg

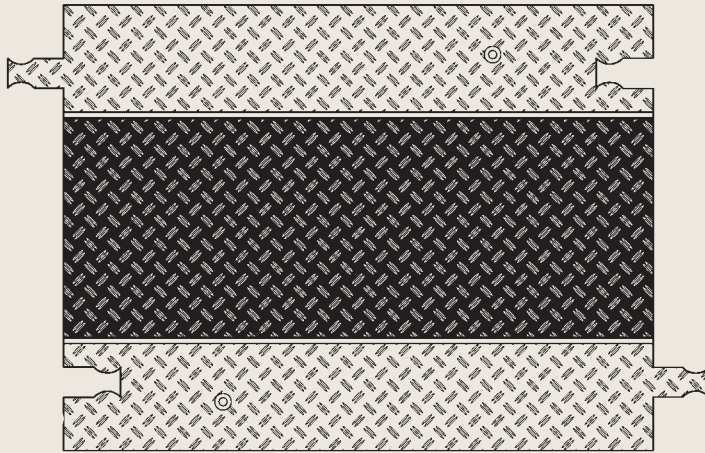

Length: 1000 mm
Width: 750 mm
Height: 70 mm
Weight: 32.6 kg



Channels:
5x 50 x 50 mm

Advantages ...

- hardness: 93° Shore A
- tensile strength: 45N/mm²/DIN 53504 and breaking strain of 600%/DIN 53504
- tear resistance: 80N/mm/DIN 53515
- impact resilience: 40–45%/DIN 53512
- abrasion loss: ca. 40 mm³/DIN 53516
- dielectric oils: e.g., for metal-manufacturing and metal-processing industries
- color: yellow-black
- practical size

... and Practical Benefits:

- load capacity of 30 tons if distributed evenly, that is, 60 kp/cm³
- next to no chance of the cable bridge breaking, even under enormous strain; high flexibility
- high mechanical load-bearing capacity, even after cut damage to the bridge
- very severe blows are absorbed by the material
- long service life, even when subjected to extreme mechanical strain
- after 10 days at +80°C no significant changes in mechanical qualities were apparent; no swelling of the material (text carried out on the BP-180 Dielectric model)
- hazard identification
- light and easy handling

Type 5.0

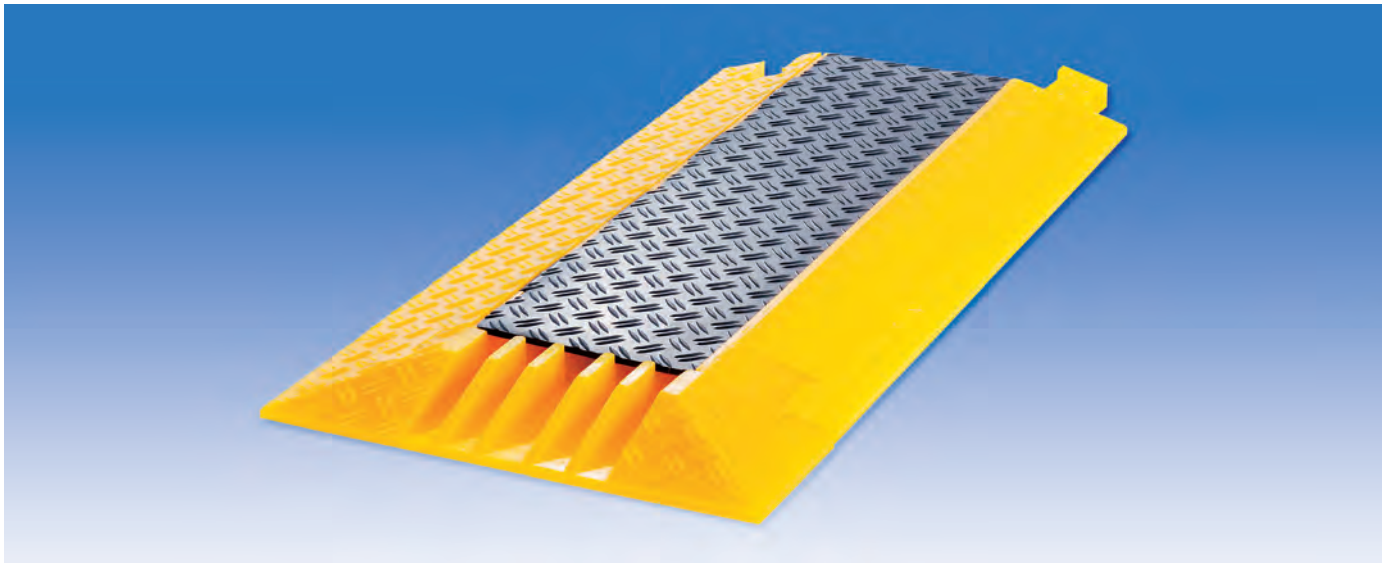

Order and Safety within Minutes

Thanks to relatively a low weight and convenient dimensions, the Type 5.0 cable bridges allow you to simply ensure mobile energy supply at professional standards within a very short time.

- diverse range of application areas
- very quick and simple assembly
- tripping hazards are mitigated

Technical Data:

- 5 passage channels
(4x 30 x 30 mm + 1x 40 x 30 mm)
- material: hot-cast polyurethane, subsequently annealed, temperature-resistant up to 80°C
- non-slip surfaces with corrugated structure
- body color: traffic yellow; cover color: black
- surface resistance: 1012 ohm (109 antistatic)
- dielectric strength: 15 kV/mm

Description	Dimensions (L x W x H)	Weight	Gradient Angle	Order No.
Bridge piece 5.0	900 x 510 x 50 mm	15.0 kg	ca. 15°	5.0
End piece 5.0	175 x 510 x 50 mm	2.6 kg	ca. 15°	5.0 E
Bridge piece 5.0 antistatic	900 x 510 x 50 mm	15.0 kg	ca. 15°	5.0 X
End piece 5.0 antistatic	175 x 510 x 50 mm	2.6 kg	ca. 15°	5.0 E X

Small on the outside, big on the inside

The 30 x 30 mm channels are for instance suitable for accommodating our INDUSTRIEFLEX®07 cables up to a size of 5 x 16 mm².

ELSPRO cable bridges implement systems engineering to address a variety of application areas. It strives for simple assembly in a short amount of time, for example when securing cables laid across roads.



– other models on request / subject to modification and errors –

ELSPRO Cable Bridges for Temporary Mobile Energy Supply Type 5.1



Length: 175 mm
Width: 510 mm
Height: 50 mm
Weight: 2.6 kg

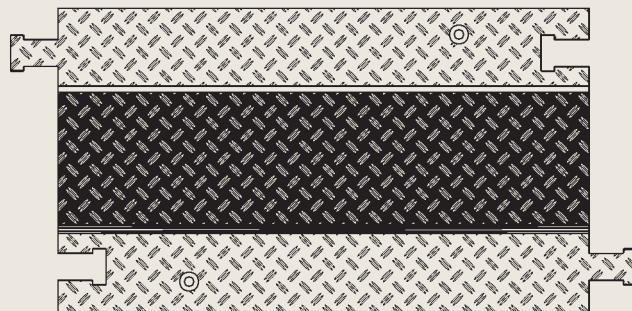

Length: 900 mm
Width: 510 mm
Height: 50 mm
Weight: 15.0 kg

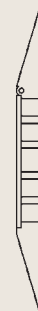

Channels:
4x 30 x 30 mm
1x 40 x 30 mm

Advantages ...

- hardness: 93° Shore A
- tensile strength: 45N/mm²/DIN 53504 and breaking strain of 600%/DIN 53504
- tear resistance: 80N/mm/DIN 53515
- impact resilience: 40–45%/DIN 53512
- abrasion loss: ca. 40 mm³/DIN 53516
- dielectric oils: e.g., for metal-manufacturing and metal-processing industries
- color: yellow-black
- practical size

... and Practical Benefits:

- load capacity of 30 tons if distributed evenly, that is, 60 kp/cm³
- next to no chance of the cable bridge breaking, even under enormous strain; high flexibility
- high mechanical load-bearing capacity, even after cut damage to the bridge
- very severe blows are absorbed by the material
- long service life, even when subjected to extreme mechanical strain
- after 10 days at +80°C no significant changes in mechanical qualities were apparent; no swelling of the material (text carried out on the BP-180 Dielectric model)
- hazard identification
- light and easy handling

Type KB3X35

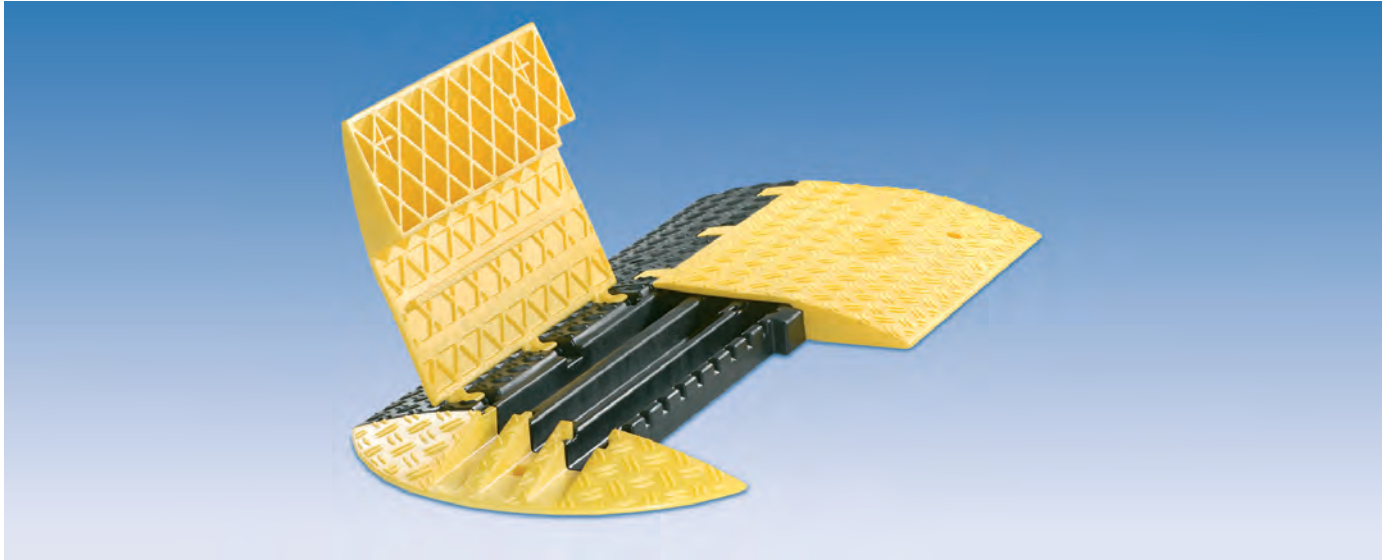

Lightweight - Take the Next One ...

The KB3X35 is an ultra-light premium product made by ELSPRO, featuring an innovative folding mechanism*. Two through holes for fixation guarantee additional opportunities for anchoring the cable bridge. By affixing the yellow ramp cover with the ground below using screws, it is possible to securely close the cable bridge system.

Technical Data:

- load capacity of 9 tons if distributed evenly
- 3 passage channels, each 35 mm in diameter
- material: injection-molded polypropylene
- temperature-resistant from -40° C to +60° C
- non-slip surface with corrugated structure
- color: hazard identification black-yellow; end piece: yellow

Description	Model	Surface resistance	Dimensions (L x W x H)	Weight	Gradient Angle	Order No.
Bridge piece KB3X35			500 x 500 x 55 mm	4,00 kg	ca. 20°	KB3X35
End piece KB3X35			160 x 500 x 55 mm	0,85 kg		KB3X35E
Bridge piece KB3X35	antistatic	< 10 ⁹ Ohm	500 x 500 x 55 mm	4,00 kg		KB3X35X
End piece KB3X35	antistatic	< 10 ⁹ Ohm	160 x 500 x 55 mm	0,85 kg		KB3X35EX

The ELSPRO cable bridge system KB3X35 is designed for diverse fields of use. The system is easy to assemble in a short period of time, which makes it especially suitable for the protective laying of cables, for instance at street festivals, weekly markets, or music and sports events. Monitored crossing by heavy trucks is permitted.

- diverse range of application areas
- very quick and simple assembly
- tripping hazards are mitigated

*German patent
no. 102007018590.3



– other models on request / subject to modification and errors –

Type KB3X35

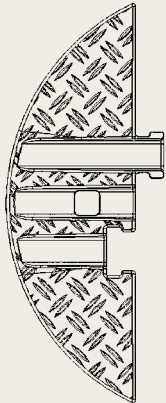

Length: 160 mm
Width: 500 mm
Height: 55 mm
Weight: 0.85 kg

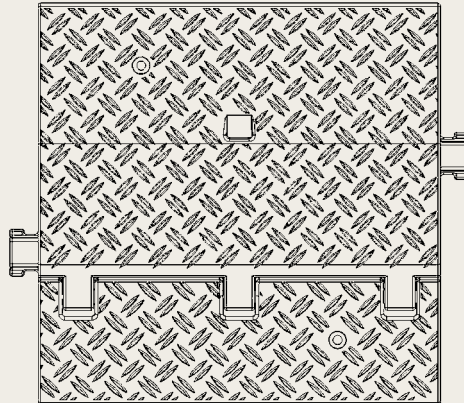

Length: 500 mm
Width: 500 mm
Height: 55 mm
Weight: 4.00 kg



Channels:
3x 35 x 35 mm

FEATURES AND QUALITIES:

- load capacity of 9 tons if distributed evenly
- next to no chance of the cable bridge breaking, even under significant strain; high flexibility
- severe blows are absorbed by the material
- long service life, even when subjected to mechanical strain
- hazard identification yellow-black
- light and easy handling thanks to practical size and very lightweight design

Special Models on Request:

- imprinting of company name/logo
- different color combinations

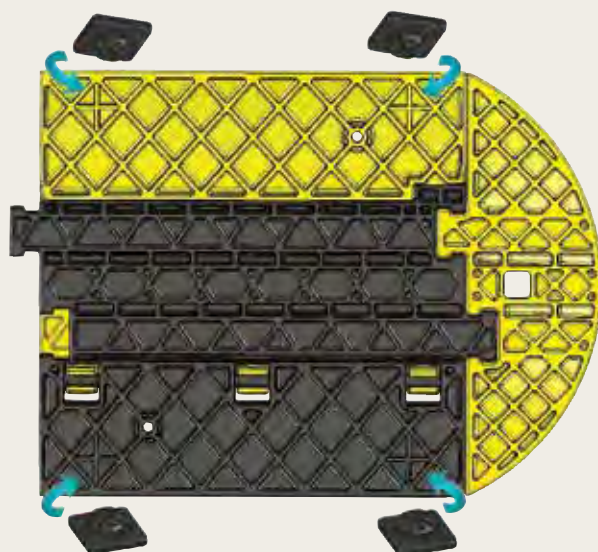

Accessories:

Stopper Set (4 pieces)

Order No.

KB3X35S

The underside of each bridge section has been prepared for the addition of four diamond-shaped stoppers made of non-slip elastomer. They improve the resting qualities of smooth surfaces.

Type BB1X20

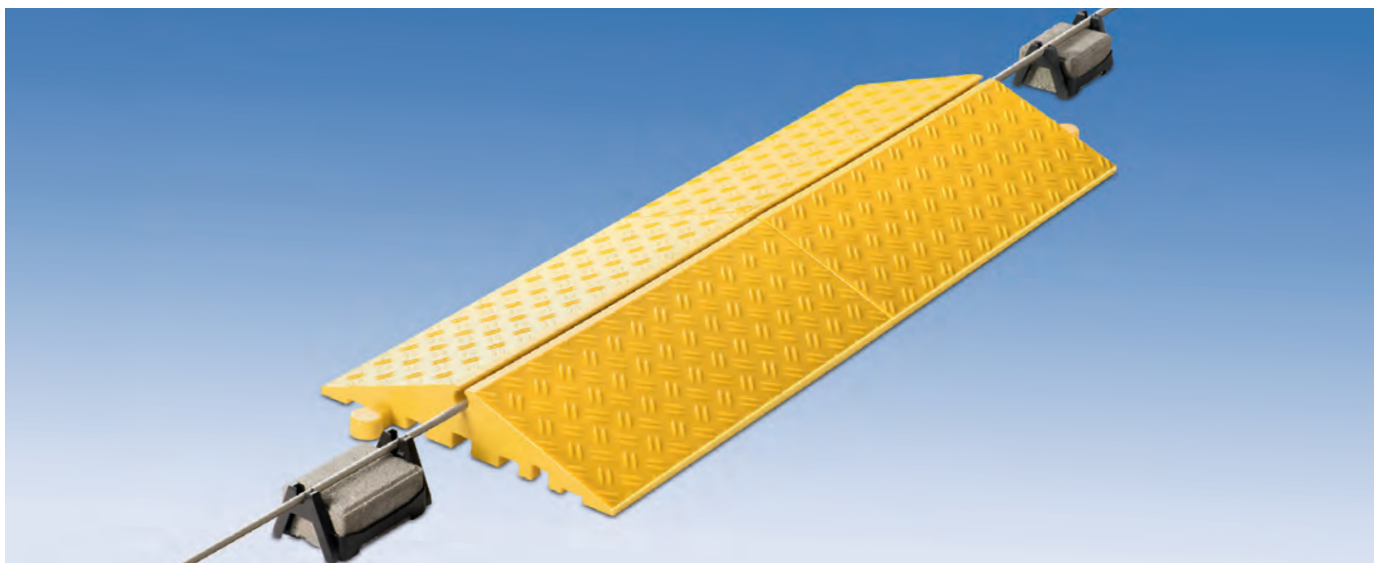

Minimal Effort – Large Impact ...

The BB1X20 represents innovation in the field of lightning protection.

Challenge:

Most buildings with flat roofs have lightning protection systems that are installed at an interval to the roof using special fastening technology. These lightning protection systems are frequently subject to damage because escape paths and operational routes lead across the roof. Damaged lightning conductors are functionally impaired, with repairs or potential damage usually proving to be costly.

ELSPRO Solution: ELSPRO lightning protection alleviates tripping hazards on flat roofs.

- no maintenance costs
- escape paths and operational routes are defined and clearly marked as such

Technical Data

- 1 passage channel, 20 mm in diameter
- material: special polyurethane OLAPRENE
 - high resistance to hydrolysis and microbes
 - strong ozone- and UV-resistance
 - specially designed for low-temperature applications
 - highest possible dynamic load-bearing capacity
 - elaborate annealing method (see description on reverse side)
- temperature-resistant from -35° C to +80° C
- non-slip surface with corrugated structure
- color: danger identification yellow

Description	Dimensions (L x W x H)	Weight	Gradient Angle	Order No.
Bridge piece	500 x 380 x 72 mm	6.40 kg	ca. 20°	BB1X20



– subject to modification and errors –

Type BB1X20

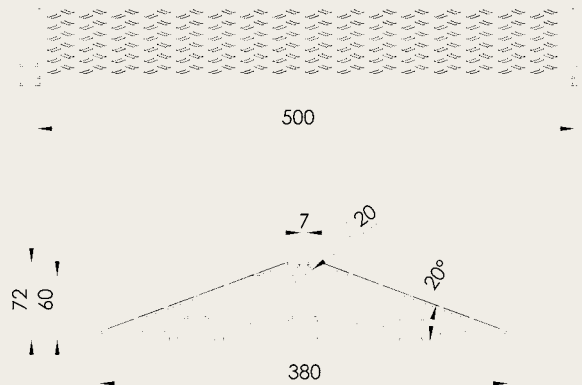
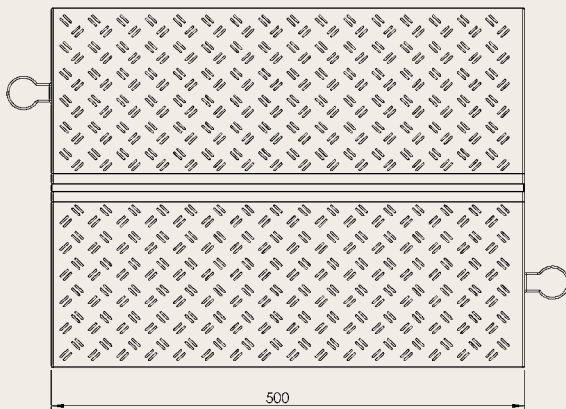

Length: 500 mm
Width: 380 mm
Height: 72 mm
Weight: 6.40 kg

Channels:
1 x \varnothing 20 mm

FEATURES AND QUALITIES:

- expected service life of \geq 12 years without any loss of quality
- high UV resistance
- high temperature resistance
- accommodates high water load
- hazard identification yellow
- light and easy handling thanks to practical size
- compatible with standard lightening protections systems (8-10 mm round wire)
- patent pending

Production Methods:

1. the liquid components are placed under vacuum (no air pockets) at 95°C to facilitate a reaction
2. the prepared liquid raw material is pour into aluminum forms
3. the form sections are then annealed in special tempering ovens for at least 16 hours at 100°C
4. the annealing process induces a process of artificial ageing in order to achieve the desired physical properties

In the case of existing systems with 8 mm of round conductor wire, the bridge is slid under the conductor and the round wire is lowered into the recess with minimal pressure. That's all! Any unintentional or independent loosening of the round conductor is not possible due to the slightly narrowed opening!

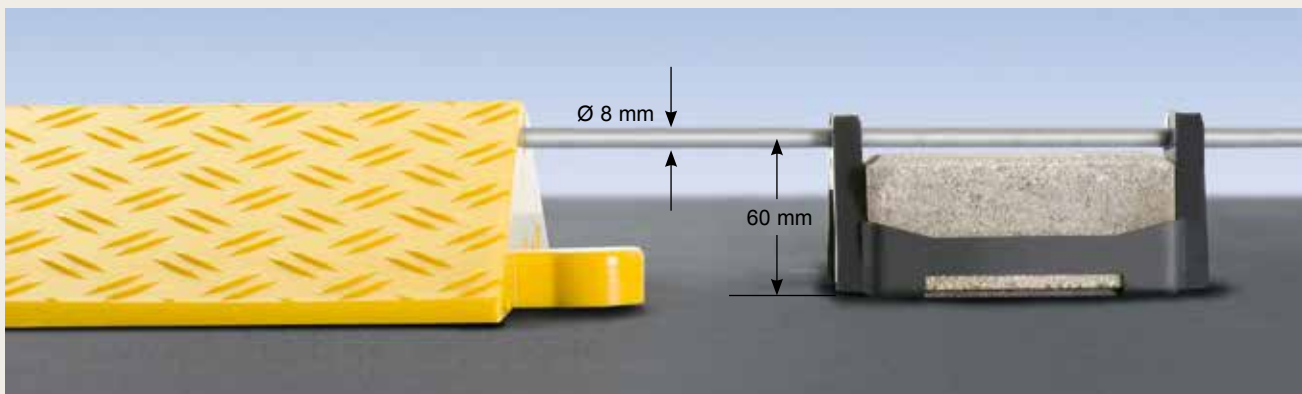

– subject to modification and errors –

Types SB und SBG

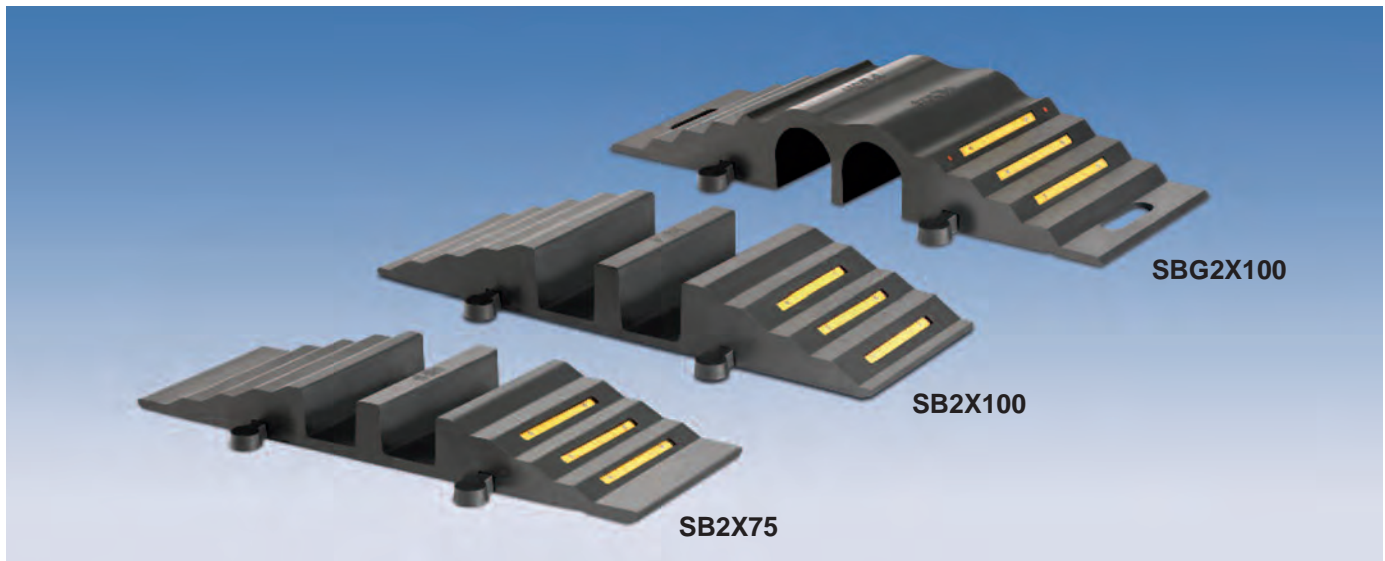

Bring On the Water!

The ELSPRO hose bridge series guarantees the professional laying of hoses for mobile water supply and sewage disposal. The connecting pieces, which are screwed from one side, ensure strong cohesion and facilitate further extensions. The solid rubber material allows for a very good fit on uneven ground and thus promotes high non-slip qualities. Yellow warning stripes on the sides serve to heighten visibility. The hose bridge type SBG2X100 is mainly suitable for light traffic and for keeping pedestrians safe, which is why this bridge model is additionally equipped with reflectors for even better visibility.

Technical Data

- 2 passage channels for hoses with a max. diameter of 75/100/100 mm each
- load capacity if distributed evenly:
 - SB2X75 max. 44 t
 - SB2X100 max. 44 t
 - SBG2X100 max. 5 t
- material: solid rubber
- temperature-resistant from -16° C to +50° C
- color: black with lateral yellow warning stripes
- SBG2X100 additionally features reflectors

Description	Dimensions (L x W x H)*	Max. Hose Diameter	Weight	Gradient Angle	Order No.
Bridge piece SB2X75	855 x 302 x 84 mm	75 mm	13.0 kg	ca. 12°	SB2X75
Bridge piece SB2X100	830 x 320 x 102 mm	100 mm	16.0 kg	ca. 19°	SB2X100
Bridge piece SBG2X100	850 x 300 x 125 mm	100 mm	20.0 kg	ca. 16°	SBG2X100



* All measurements are reference values and may deviate slightly.

- other models on request / subject to modification and errors -

Electrical Welding Products

– Plugs, Connectors,
Pliers, Cables,
Accessories



ELSPRO Welding Products

Electrode Holder Pliers

Fig.	Welding Current/ED	Cable connection	Order No.
1.	300 A/35% 250 A/60%	max. 50 mm ²	9ZE300
2.	400 A/35% 300 A/60%	max. 70 mm ²	9ZE400
3.	600 A/35% 350 A/60%	max. 95 mm ²	9ZE600

– other electrode holder pliers on request –

Welding Set

Electrode holder with **super-flexible** welding cable and plug

Fig.	Length	Cross-Section	Sheath Color	Order No.
1.	3 m	25 mm ²	schwarz	SET2503
	5 m	25 mm ²		SET2505
2.	3 m	35 mm ²	orange	SET3503
	5 m	35 mm ²		SET3505
3.	3 m	50 mm ²	rot	SET5003
	5 m	50 mm ²		SET5005

– other cable lengths and types on request –

Welding Cable Connectors EN 60974.12-IEC 974.12

- insulated solid rubber plug components with latch cone contact
- with clamping collet and clamping screw

16-25 mm ²	9K025
35-50 mm ²	9K050
70-95 mm ²	9K095
120 mm ²	9K120

Welding Cable Plugs EN 60974.12-IEC 974.12

- insulated solid rubber plug components with latch cone contact
- with clamping collet and clamping screw

16-25 mm ²	9S025
35-50 mm ²	9S050
70-95 mm ²	9S095
120 mm ²	9S120

Built-In Welding Jacks

10-25 mm ²	EB025
35-70 mm ²	EB050
70-95 mm ²	EB095
120 mm ²	EB120

Built-In Welding Plugs

10-25 mm ²	ES025
35-70 mm ²	ES050
70-95 mm ²	ES095
120 mm ²	ES120



ELSPRO Welding Products

Earthing Clamps (brass with copper brackets):

Fig.	Welding Current	Order No.
ALFA 1	500 A	EKA01
ALFA 2	600 A	EKA02

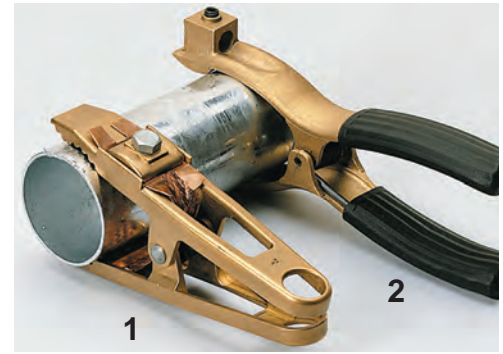

Earthing Clamps (galvanized steel sheet with copper brackets):

Fig.	Welding Current	Order No.
BETA 1	200 A	EKB01
BETA 2	500 A	EKB02

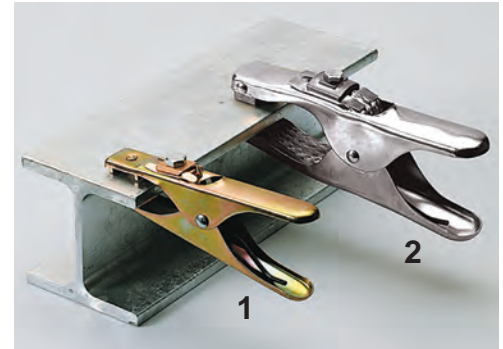

Earthing Clamps (galvanized steel sheet with copper brackets):

Fig.	Welding Current	Order No.
GAMMA 1	150 A	EKG01
GAMMA 2	200 A	EKG02
GAMMA 3	400 A	EKG03

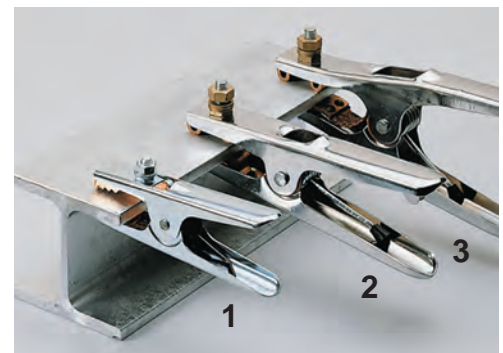

Pol-Welding Screw Clamps (cast steel with copper brackets):

Fig.	Welding Current	Order No.
DELTA 1	600 A	EKD01
DELTA 2	400 A	EKD02



Battery Clamps (fully insulated galvanized steel sheet with copper brackets):

Model	Welding Current	Order No.
black straight	600 A	BK01
red straight	600 A	BK02
black angled	600 A	BK01W
red angled	600 A	BK02W



* customized earthing clamps, pol-welding screw clamps,
and battery clamps according to customer specifications *
– other items on request / subject to modification and errors –

ELSPRO®

POWERSTATION

Off-grid power supply for industry
and emergency services



Mobile POWERSTATION

Off-grid power supply for industry and emergency services

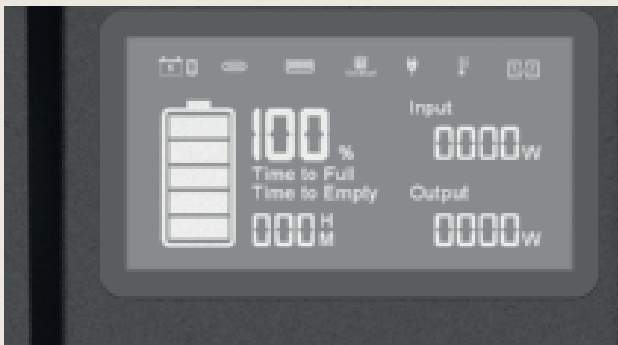
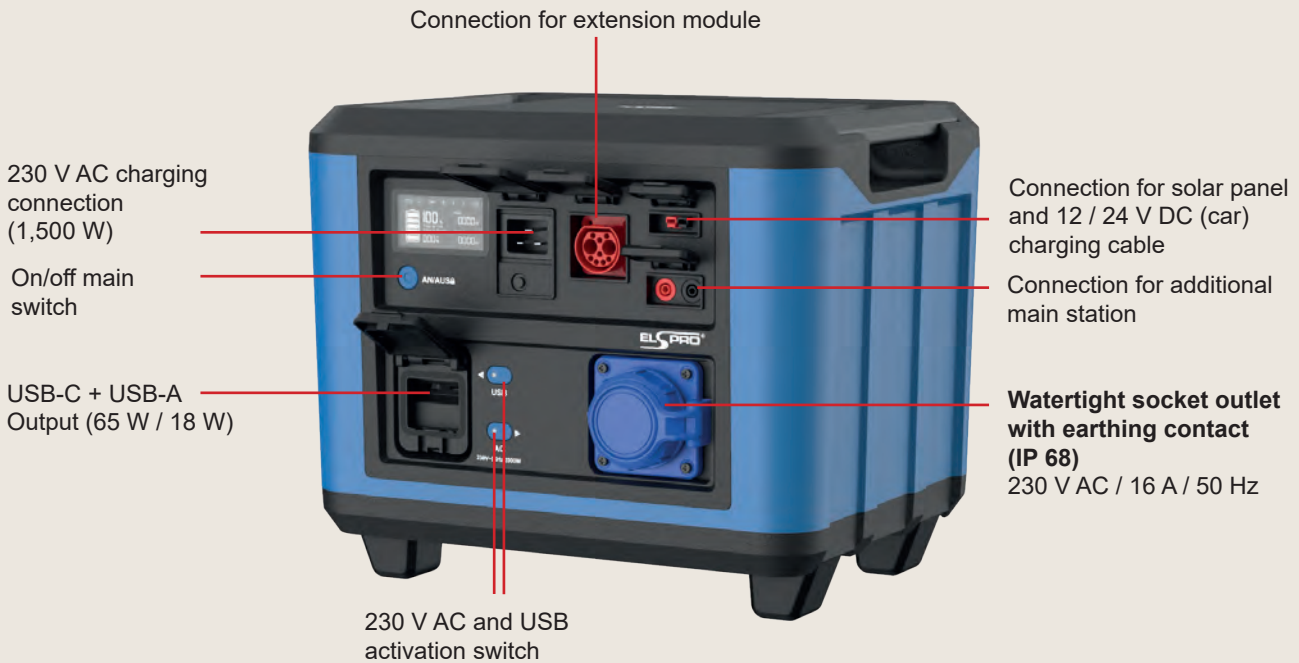

LCD display with real-time information

- Capacity, visual and in %
- Operating and charging time: in real time and to the minute
- Input power and output power
- 230 V AC / USB outputs active
- Number of connected extension modules
- Status display



– Subject to changes and errors –

Mobile POWERSTATION

Mains-independent power supply



TECHNICAL DATA:

Main station

Order no.	EMPS2000
Continuous power	2,000 W
Top performance	4,000 W
Capacity	1.5 kWh
Outputs	1 socket outlet with earthing contact - without \llcorner - 16 A / 230 V / IP 68 1 USB-C (65 W) / 1 USB-A (18 W)
Protection type	IP 65
Charging time	1 hour to 70% / 1.5 hours to 100%
Capacity display	LCD display
Ambient temperature	-20°C to +40°C
Protection class	1
Dimensions	385 x 322 x 310 (W x H x D)
Weight	26 kg

Supplied with 230 V AC charging cable (2 m) H07RN-F (item no. EMPS008)

Extension module

Order no.	EMPS2000EM
Capacity	1.5 kWh
Protection type	IP 65
Capacity display	8 LEDs
Ambient temperature	-20°C to +40°C
Dimensions	385 x 230 x 306 (W x H x D)
Weight	19 kg

Delivery includes connection cable to the main station (item no. EMPS007)

– Subject to changes and errors –

Mobile POWERSTATION

Off-grid power supply for industry and emergency services

Cost savings

Time saving

Increased safety

ELSPRO POWERSTATION - the mobile power source for demanding environments

The mobile ELSPRO POWERSTATION is a reliable portable power source for challenging applications and provides power wherever and whenever it is needed. It is perfect for spontaneous emergencies, temporary construction and assembly sites and use in remote areas - quietly and without emissions. If the ELSPRO POWERSTATION is not required for an extended period of time, it remains ready for use for months due to its extremely low self-discharge rate of < 3% per month.

SPECIAL FEATURES:

LITHIUM-IRON PHOSPHATE - the particularly safe lithium-ion technology

- **32 high-performance LiFePO4 cells** (51.2 V DC, 30,000 mAh, 1,536 Wh)
- **Particularly safe:** certified according to UN 38.3 and UL62133
- **High operational reliability:** the battery is fully charged in 1.5 hours and the self-discharge rate is < 3% / month
- **Environmentally friendly:** LiFePO4 batteries can be largely recycled and individual battery cells or the entire POWERSTATION battery can be replaced
- Cobalt-free and **long service life** conserves resources

INCREASED SAFETY

- **No risk of fire/explosion** due to lithium iron phosphate battery
- Suitable for permanent outdoor use thanks to its robust design and high degree of protection
- All outputs must be activated before each operation
- **Self-closing hinged cover** in front of all inputs and outputs
- **Automatic switch-off** after 30 minutes if no loads are connected
- LCD display with status and **remaining capacity display**
- **Emergency power function** for an uninterruptible power supply (UPS):
When a device is connected to the POWERSTATION while it is plugged into the mains, the device is powered directly by the grid. If the power fails, the POWERSTATION switches to emergency power mode within ≤ 10 ms and supplies the load directly



ADDITIONAL PROTECTION:

Internal, automatic fire extinguishing unit:
Nitrogen is released when a sensor detects significant overheating inside the housing

[scan here for a video](#)



COST SAVINGS

- High **Battery service life** and **Cycle stability** → after 2,500 charging cycles ≥ 80% of the original capacity
- **Easy to repair:** high availability of spare parts
- **Charging via solar** (800 W / 12-60 V DC) through Anderson connection
- **robust and resistant** die-cast aluminium housing, plastic powder-coated
- **Low operating costs:** no costs for petrol, oil and maintenance
- **Intelligent battery management system (BMS)** - monitors and controls the complete charging and discharging process of every single battery cell in the POWERSTATION: overcharge protection / overdischarge protection / overvoltage protection / overcurrent protection / short-circuit protection / overheating protection / low temperature protection

TIME SAVING

- **Easy handling:** easy to stow away thanks to its compact design and **quickly ready for use** thanks to easy transport
- **Maintenance-free** thanks to passive cooling - no tedious cleaning of fans or filters necessary
- **Fast charging** from 0 to 100% in **1.5 hours** thanks to 1,500 W charging power
- **Can also be charged in the car** (12 / 24 V DC)

– Subject to changes and errors –

Mobile POWERSTATION

Off-grid power supply for industry and emergency services

CAPACITY expandable:

Modular expansion to a capacity of up to 6 kWh



PERFORMANCE AND CAPACITY expandable:

Modular expansion to a continuous output of 4,000 W (8,000 W peak output) – by connecting two main stations – and a capacity of up to 7.5 kWh

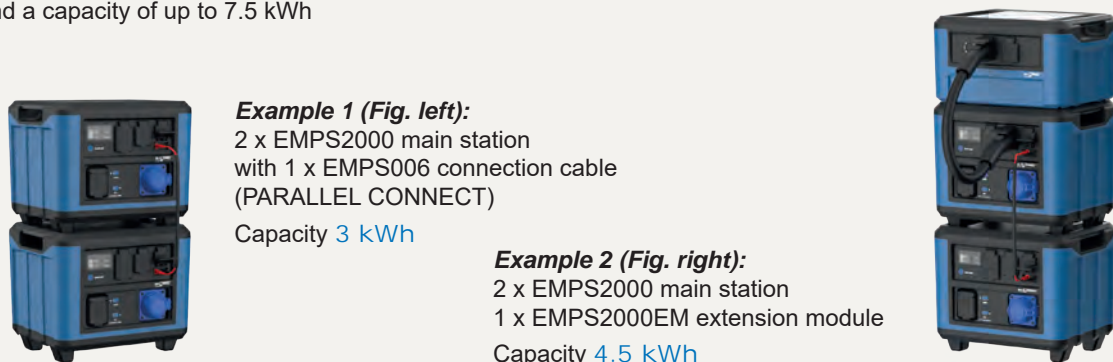

Example 1 (Fig. left):
2 x EMPS2000 main station
with 1 x EMPS006 connection cable
(PARALLEL CONNECT)
Capacity 3 kWh

Example 2 (Fig. right):
2 x EMPS2000 main station
1 x EMPS2000EM extension module
Capacity 4.5 kWh

OPERATING TIME of various consumers connected to a main station (1.5 kWh):

Drilling machine	N8LED 2.1	Angle grinder	Submersible pump
 600 W 2:30 hrs. 5:00 hrs*	 360 W 04:10 hrs. 08:20 hrs*	 1,500 W 01:00 hrs. 02:00 hrs*	 1,300 W 01:09 hrs. 02:18 hrs*
Laptop	Spotlight QV LED 100	Hammer drill	Water vacuum cleaner
 50 W 30:00 hrs. 60:00 hrs*	 100 W 15:00 hrs. 30:00 hrs*	 1,000 W 01:30 hrs. 03:00 hrs*	 1,900 W 00:47 hrs. 01:34 hrs*

* Main station + extension module or 2 x main station (3 kWh)

– Subject to changes and errors –

Mobile POWERSTATION

Off-grid power supply for industry and emergency services



Steel protective frame for ELSPRO POWERSTATION



Transport trolley for ELSPRO POWERSTATION



ELSPRO POWERSTATION with safety distributor HILDEN

ACCESSORIES AND SPARE PARTS:	Order no.
Steel protective frame with carrying handles	EMPS-SG
Transport trolley with telescopic handle (max. load capacity 100 kg)	EMPS-TK
Protective cover (not shown)	EMPS-SH
Replacement cover (AC-IN)	EMPS001
Replacement lid (EXTRA BAT+)	EMPS002
Replacement cover (PV-INPUT)	EMPS003
Replacement lid (PARALLEL CONNECT)	EMPS004
Replacement cover (USB-C / USB-A)	EMPS005
Connection cable (PARALLEL CONNECT)	EMPS006
Replacement cable (EXTRA BAT+)	EMPS007
Spare charging cable (2 m standard H07RN-F)	EMPS008
Charging cable 12 / 24 V DC (car)	EMPS009
Solar charging cable (PV-INPUT)	EMPS011
Replacement stand cover	EMPS012
Charging cable (5 m INDUSTRIEFLEX® 07 HT)	S/PG/5/KGK

Mobile solid rubber distributor HILDEN **1310052**
 in accordance with DGUV Information 203-032
 3 socket outlets with earthing contact
 (3 pole / 16 A / 230 V)
 3 RCD residual current circuit-breaker
 (2 pole / 25 A / 30 mA / type A)

10 m extension cable **S10KPG**
 INDUSTRIEFLEX® 07 HT 3G1.5 mm²
 H07RN-F / H07RN8-F / H07BN4-F
 Earthing contact plug and coupling /
 3 pol. / 16 A / 230 V

– additional special distributors on p. 5.12 and on request /
 also available as pressurised water-tight versions –

COMPACT DIMENSIONS:

Main station

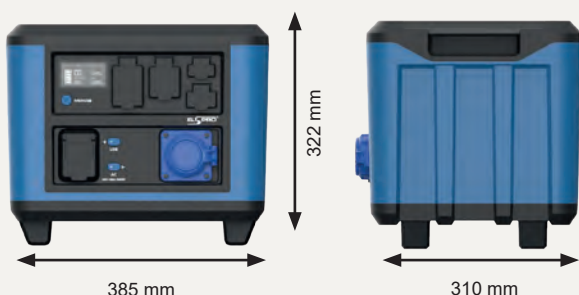

Extension module

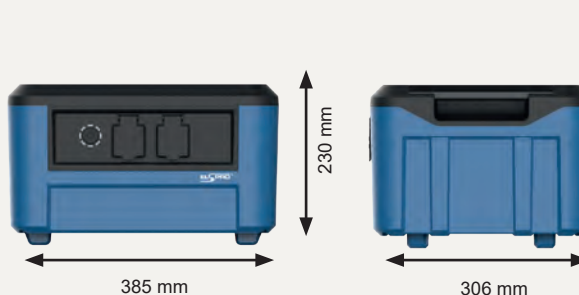

– Subject to changes and errors –

QUALITY GUARANTEED

Our products reflect the current state of technology and conform to German and European norms. We are certified according to the standard DIN EN ISO 9001.

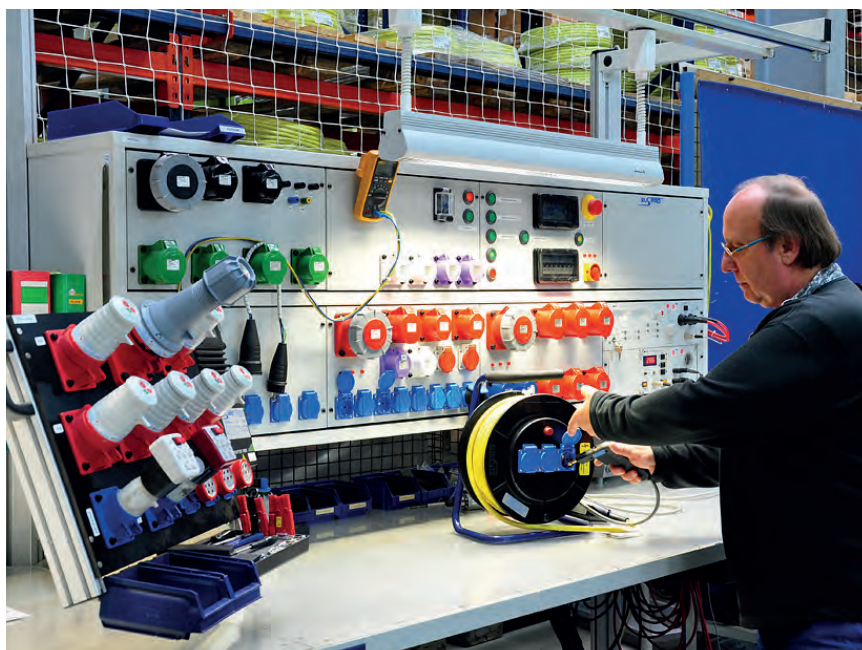

ELSPRO = ELECTROTECHNICAL SAFETY PRODUCTS

Since the company was founded in April 1986, safety and personal protection when dealing with electrotechnical equipment has always been the primary focus for ELSPRO.

Reliable, flexible and service-orientated – our focus is on long-term cooperation

ELSPRO products offer you maximum safety in the professional distribution of light and electricity. The implementation of your product requirements are always based on state-of-the-art technologies while being compliant with the latest directives.

We offer „technology without compromise“, are happy to advise you and develop tailor-made solutions for you.

Creative, customer-orientated and close to the market – we grow with your requirements

Constant training and consistent product development over many years form the basis of our extensive range of electrotechnical safety products. Innovative product solutions arise constantly from day-to-day business thanks to partnership-oriented cooperation between our qualified staff and discerning customers.

ELSPRO – Electrotechnology at the highest level

From our headquarter in Hilden, we supply the European market with high quality ELSPRO products. Individual consultancy and order-related production are a key part of our day-to-day business. Customer-orientated support is provided by an extensive network of regional offices and expert advice from our qualified field staff.

Upon request, your personal contact will be delighted to present products which may interest you at your premises.

On the safe side with ELSPRO

Together we investigate your individual requirements. Our departments will then work out dedicated electrotechnical product solutions of the highest safety standard, true to our motto „technology without compromise“.

As a manufacturer, we offer you the following benefits:

- production to customer specifications
- on-site support by our technical field staff
- qualified contact persons in the head office
- detailed knowledge of the current regulations



ELSPRO®

ELSPRO Elektrotechnik GmbH & Co. KG
Kleinhülsen 47 · 40721 Hilden · Germany

- ☎ +49 2103 9710-45
- ☎ +49 2103 9710-80
- ✉ sales@elspro.de
- 🌐 <https://www.elspro.de/en>

