



CONFIGURATIONS:

Voltage	Power	Light source	Luminous flux	Colour	Dimensions in cm	Weight	Order no.
100-240 V AC 50/60 Hz	100 W	High-Power-COB LED	10.000 - 2.000 lm	blue-black	H = 27,7 W = 24,4 D = 8,5	4,3 kg	QVL100/5

SPECIAL FEATURES:

- Robust powder-coated die-cast aluminium housing with rubberised edge and lens protection
- Small space requirement due to compact design
- Easy to transport thanks to rubberised carrying handle
- 5-level dimming function (10,000 / 8,000 / 6,000 / 4,000 / 2,000 lm)
- Light output display (10,000 - 2,000 lm) on the back of the light
- A continuously adjustable 180° swivelling base allows for a variable alignment of the light beam (Fig. 1)
- 120° beam angle for uniform area illumination
- with brightness memory function
- Fluorescent reflector integrated into the lens makes it easier to find the light in the dark (Fig. 2)
- Integrated USB port (output 5V 1A) for charging mobile devices (Fig. 3)
- Protection class IP 67 - dust and waterproof
- Impact resistance IK 07 - impact-resistant and resistant to mechanical stress
- Base prepared for mounting the ELSPRO base holder with DIN pin receptacle Ø 30 mm (Order No. TV001/4) for tripod mounting of the light
- Supply cable with plug: 5m INDUSTRIEFLEX 05 3G1.0 mm² - Copper class 6: ultra-fine stranded and therefore highly flexible

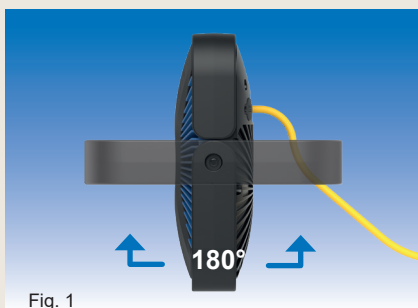

Fig. 1



Fig. 2



Fig. 3

Version with rechargeable battery see from p. 22.02.1

– Subject to changes and errors –



Tripod Type DELTA 5

ACCESSORIES:

- Tripod Type DELTA 5 with Ø 30 mm DIN pin
 - Black aluminium
 - height when collapsed: 102 cm
 - Shock-absorbed / air-damped lowering
 - Maximum height when set up: 285 cm
 - Maximum height when set up: 104 cm
 - Maximum footprint diameter: 109 cm
 - max. load max. 13/17 kg
 - Tripod weight is approx. 3.3 kg
 - Completely pre-assembled

Order no.

TV7741SA



QV LED 100 on DELTA 5 tripod

TV001/4

- Base mount TV001 including DIN pin holder Ø 30 mm with fixing material for QV LED 100

TV001/4



Magnetic holder QVL.2MAG

- Magnetic holder (stainless steel holding rail for clamp attachment with 2 holding magnets) for QV LED 100

QVL.2MAG

– additional tripods and trusses from p. 13.1 / Subject to changes and errors –